



**DCS & Labeling Worldwide**

**CL408-412e  
PRINTER**



**SUPPLEMENTAL  
OPERATOR MANUAL**

**SATO America, Inc.**

10350A Nations Ford Road  
Charlotte, NC 28273

Main Phone: (704) 644.1650  
Technical Support Hotline: (704) 644.1660  
Technical Support Fax: (704) 644.1661  
E-Mail: [satosales@satoamerica.com](mailto:satosales@satoamerica.com)  
[techsupport@satoamerica.com](mailto:techsupport@satoamerica.com)  
[www.satoamerica.com](http://www.satoamerica.com)

**WARNING**

**THE EQUIPMENT REFERENCED IN THIS DOCUMENT COMPLIES WITH THE REQUIREMENTS IN PART 15 OF FCC RULES FOR A CLASS B COMPUTING DEVICE. OPERATION OF THIS EQUIPMENT IN A RESIDENTIAL AREA MAY CAUSE UNACCEPTABLE INTERFERENCE TO RADIO AND TV RECEPTION.**

# TABLE OF CONTENTS

## INTRODUCTION

About This Manual	1-2
General Description	1-3
Control Features	1-4

## TECHNICAL DATA

Physical Characteristics	2-2
Power	2-2
Environmental	2-2
Processing	2-2
Interface Modules	2-2
Interface Modules	2-2
Print	2-2
Sensing	2-3
Media	2-3
Ribbon	2-3
Command	2-3
Character Font Capabilities	2-4
Barcode Capabilities	2-5

## INSTALLATION

Unpacking & Parts Identification	3-2
Printer Installation	3-3
Site Location	3-3
Cable Connection	3-3
Media Selection	3-4
Media & Ribbon Loading	3-4
Operational Mode Selection	3-6
Tear-Off Mode	3-6
Continuous Mode	3-6
Interface Selection	3-8
RS232C High-Speed Serial Interface	3-8
IEEE1284 Parallel Interface	3-11
Universal Serial BUS (USB) Adapter	3-12
Local Area Network (LAN) Ethernet	3-12
802.11G Wireless	3-13
EXT Accessory Port	3-15
All Interfaces	3-18
Accessories Installation	3-20
Interface Installation	3-20

# PRINTER CONFIGURATION

<b>Printer Configuration</b>	<b>4-2</b>
<b>Dipswitch Settings</b>	<b>4-3</b>
<b>Configuration Modes</b>	<b>4-6</b>
Normal Mode	4-6
Advanced Mode	4-7
User Download Mode	4-8
Service Mode	4-9
Card Mode	4-10
Protocol Initialization Mode	4-11
Counters Mode	4-12
Test Print Mode	4-13
Boot Download Mode	4-14
Flash Memory Download Mode	4-15
Default Settings Mode	4-16
Hex Dump Mode	4-17
Maintenance Mode	4-18
<b>Menu Definition Tables</b>	<b>4-19</b>

# TROUBLESHOOTING

<b>Error Signal Troubleshooting</b>	<b>5-2</b>
<b>Troubleshooting Table</b>	<b>5-3</b>
<b>Interface Troubleshooting</b>	<b>5-5</b>
Parallel Interface	5-5
RS232 Serial Interface	5-5
Universal Serial Bus (USB) Interface	5-5
LAN Ethernet Interface	5-6
802.11G Wireless Interface	5-6
Centronics Interface	5-6
<b>Test Print Troubleshooting</b>	<b>5-7</b>
Hex Dump Mode	5-7
Test Label Printing	5-8
Sample Test Label	5-9

# MAINTENANCE

<b>Cleaning Procedures</b>	<b>6-2</b>
<b>Replacement Procedures</b>	<b>6-3</b>
Print Head	6-3
Interface Board	6-5
Fuse	6-6
<b>Adjustment Procedures</b>	<b>6-7</b>
Print Head Balance	6-7
Print Head Alignment	6-8
Ribbon Guide	6-9
Label Sensor Positioning	6-10
Ribbon Spindle Tensioning	6-11
Operational Adjustments	6-12
Pitch	6-12
Offset	6-12
Darkness	6-12

# APPENDIX

<b>Print Setup Dimensions</b>	<b>7-2</b>
<b>Label Reference Position</b>	<b>7-3</b>
<b>Glossary</b>	<b>7-4</b>

# 1

## **INTRODUCTION**

- **About This Manual**
- **General Description**
- **Control Features**

## ABOUT THIS MANUAL

---

This manual is laid out consistent with the product discussed and provides all of the information required for printer installation and operation by the purchaser.

This manual also incorporates the use of special information boxes. Examples of these boxes and the type of information provided in each, are below.

**WARNING:** PROVIDES INFORMATION THAT, IF UNHEEDED, MAY RESULT IN PERSONAL INJURY.

**CAUTION:** PROVIDES INFORMATION THAT, IF UNHEEDED, MAY RESULT IN EQUIPMENT DAMAGE.

**ATTENTION:** Provides information that is deemed of special importance but will not result in personal injury or product damage if unheeded.

**NOTE:** Provides helpful hints to assist in performing the tasks at hand.

**LCD DISPLAY:** Provides the specific display that should be visible on the LCD at that point.

A comprehensive Table Of Contents provided at the front of this manual facilitates rapid movement within. The contents identify the different Units, Chapters, and some Sections. Each references the page number of their commencement.

The pages of this manual have embedded headers and footers to assist the user in identifying his or her exact position within the manual. The header provides the unit number followed by its name. The footer identifies the product on the left, the page number in the center, and the manual's part number to the right side of the page.

Page enumeration is two-part with each separated by a hyphen. The first character set references the Unit and the second identifies the page number within that unit. Page numbers begin with the numeral one (1) at the beginning of a new unit and ascend sequentially.

# GENERAL DESCRIPTION

The CL4e series printer brings the latest in technology to the world of thermal label printing by offering high-speed data transmission, unparalleled processing speed and large amounts of integrated memory to quickly and easily manage any label printing requirement.

These printers set new benchmarks in label throughput. The new generation RSIC processor provides high performance in label production even when printing directly from standard Windows.

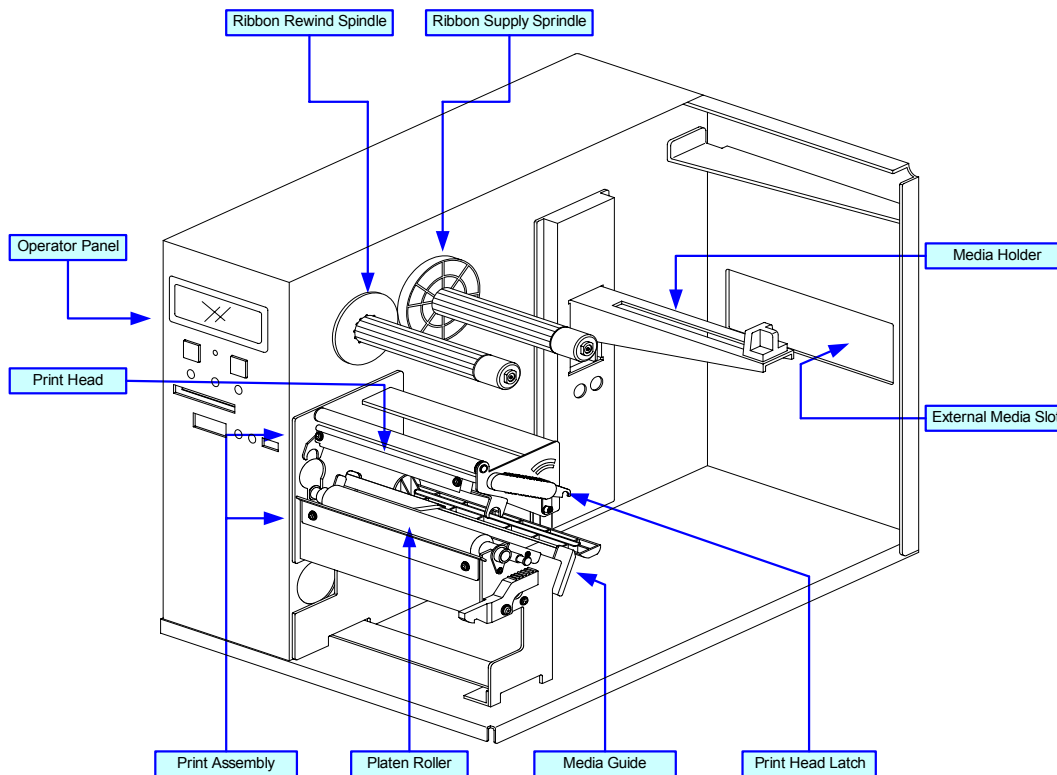

Figure 1-1a, Primary Components



## CONTROL FEATURES

This chapter identifies the interactive control features of the printer. These functions are defined generally here. More specific explanations will be found throughout this manual on how to use them.

<b>OPERATOR PANEL FEATURES</b>	
<b>LED</b>	<b>DEFINITION</b>
STATUS	<ul style="list-style-type: none"> <li>• Illuminates green when online and terminates when offline.</li> <li>• Blinks green when receiving data or the buffer is near full.</li> <li>• Illuminates or blinks red when detecting a printer error.</li> </ul>
<b>KEYS</b>	<b>DEFINITION</b>
POWER	Removes power supply at its entry to the printer.
LINE	Moves the printer from an online to offline state and vice-versa, scrolls menu options, and performs other special functions as identified in flow charts throughout this manual where applicable.
FEED	Advances the label media when pressed, selects menu options, and performs other special functions as identified in flow charts throughout this manual where applicable.
<b>POTENTIOMETERS</b>	<b>DEFINITION</b>
PRINT	Adjusts the print density resulting in a lighter or darker print image.
OFFSET	Adjusts forward or backfeed offset distance for peel, cut, or tear-off operations.
PITCH	Adjusts the print stop position (top of form).
<b>DIPSWITCHES</b>	<b>DEFINITION</b>
DSW 2, Switch 1	Determines direct thermal or thermal transfer printing.
DSW 2, Switch 2	Determines Eye-Mark or Gap Sensor function.
DSW 2, Switch 3	Enables/Disables the headcheck feature.
DSW 2, Switch 4	Enables/Disables the Hex Dump feature.
DSW 2, Switch 5	Determines Multi-Buffer Interface Receive Mode (periodic response) or Single-Item Interface Receive Mode (ENQ response)
DSW 2, Switch 6	Enables/Disables the Download Mode feature
DSW 2, Switch 7	Enables/Disables non-standard Control Code feature
DSW 2, Switch 8	Enables/Disables the emulating for earlier series printers.
DSW 3, Switches 1 - 2	Determines the printing mode: Continuous, Tear-Off, Cutter, or Dispenser.
DSW 3, Switch 3	Enables/Disables the Pitch Sensor.
DSW 3, Switch 4	Enables/Disables the backfeed function.
DSW 3, Switch 5	Enables/Disables an external device to initiate a label print for synchronization with an applicator.
DSW 3, Switches 6 - 7	Determines the polarity and signal type (level or pulse) of the external print synchronizing signal to be selected.
DSW 3, Switch 8	Enables/Disables an alternate device to reprint the last label of the print job.

Unit 1: Introduction

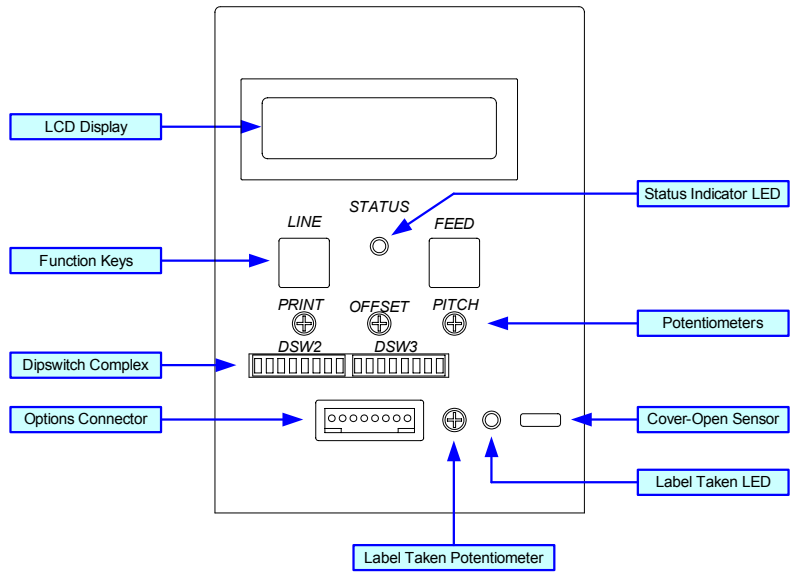

Figure 1-2, Operator Panel

# 2

## TECHNICAL DATA

- **Physical Characteristics**
- **Power**
- **Enviromental**
- **Processing**
- **Interface Modules**
- **Print**
- **Sensing**
- **Media**
- **Ribbon**
- **Command**
- **Regulatory Approvals**
- **Character Font Capabilities**
- **Barcode Capabilities**

<b>PHYSICAL CHARACTERISTICS</b>	
Width	10.67 Inches (271 mm)
Height	12.64 Inches (321 mm)
Depth	16.92 Inches (430 mm)
Weight	28.66 Pounds (13 Kg)

<b>POWER</b>	
Input Voltage	100-120/200-240 Volts AC +/- 10%, 50/60 Hertz +/-5% (selectable via jumper position)
Power Consumption	50 Watts Idle, 130 Watts Operating

<b>ENVIRONMENTAL</b>	
Operating Temperature	4 to 104°F (5° to 40°C)
Storage Temperature	23 to 140°F (-5° to 60°C)
Storage Humidity	30 to 90% RH Non-Condensing
Operating Humidity	30 to 80% RH Non-Condensing

<b>PROCESSING</b>	
CPU	32 Bit RISC
Flash ROM	4 Megabytes
Receive Buffer	2.95 Megabytes maximum, 2 Megabytes near full

<b>INTERFACE MODULES</b>	
Enhanced Parallel Port	IEEE1284
Serial Port	RS232C (9600 to 57,600 bps)
Universal Serial Bus	USB Adapter (12 Mbps)
LAN	10BASE-T/100BASE-TX Automatic Switching
Ethernet (Wireless LAN)	802.11G Wireless Wi-Fi

<b>PRINT</b>	
Method	Direct Thermal / Thermal Transfer
Maximum Speed (selectable)	2, 3, 4, 5, 6 Inches Per Second (50.8-152.4 mm)
Print Module (dot size)	.0049 Inches (.125 mm)
Resolution	CL408e: 203 Dots Per Inch (8 dpmm) CL412e: 305 Dots Per Inch (12 dpmm)
Maximum Print Width	4.09 Inches (104 mm)
Maximum Print Length	7.01 Inches (178 mm)
Pitch at EX Command	CL408e: 49.17 Inches (1249 mm) CL412e: 32.80 Inches (833 mm)

## Unit 2: Technical Data

<b>SENSING</b>	
Gap	Adjustable
Reflective Eye-Mark	Adjustable
Ribbon Near End	Enable/Disable
Media Out	Constant
Ribbon Out	Constant
Cover Open	Constant

<b>MEDIA</b>	
Width	Media Width: 0.866 to 5.04 Inches (22-128 mm) Media Width with Backing Paper: 0.984 to 5.16 Inches (25-131 mm)
Length (Continuous)	Media Length: 0.237 to 7.01 Inches (6-178 mm) Media Length with Backing Paper: 0.354 to 7.13 Inches (9-181 mm)
Length (Tear-Off)	Media Length: 0.669 to 7.01 Inches (17-178 mm) Media Length with Backing Paper: 0.787 to 7.13 Inches (20-181 mm)
Type	Roll or Fan-Fold Eye-Mark or Gap Direct Thermal or Thermal Transfer
Thickness	0.003 to 0.010 Inches (0.08-0.26 mm)
Roll Diameter	Maximum: 8.6 Inches (218.44 mm)
Core Diameter	3.0 Inches (76.2 mm)
Wind Direction	Face Inward
Fan-Fold Height	Maximum: 3.94 Inches (100 mm)

<b>RIBBON</b>	
Width	Maximum: 4.37 Inches (111 mm)
Length	1476 Feet (450 m)
Wound	Face In
Core Diameter	1 Inch (25.6 mm)
Material	Polyester film
Thickness	(5.8 +/- 0.8 to 8.3 +/- 0.6 ym)

<b>COMMAND</b>	
Standard	SATO Barcode Printer Language (SBPL) Intelligent Command
Non-Standard	N/A

<b>REGULATORY</b>	
Safety	FCC (Class B), EN 55022 (Class B)

<b>CHARACTER FONT CAPABILITIES</b>	
<b>MATRIX FONTS</b>	
XU	5 dots W x 9 dots H (Helvetica)
XS	17 dots W x 17 dots H (Univers Condensed Bold)
XM	24 dots W x 24 dots H (Univers Condensed Bold)
OA Font (OCR-A)	LM408e: 15 dots W x 22 dots H LM412e: 22 dots W x 33 dots H
OB Font (OCR-B)	LM408e: 20 dots W x 24 dots H LM412e: 30 dots W x 36 dots H
<b>AUTO SMOOTHING FONTS</b>	
XB	48 dots W x 48 dots H (Univers Condensed Bold)
XL	48 dots W x 48 dots H (Sans Serif)
<b>VECTOR FONT</b>	
	Proportional or Fixed Spacing Font Size 50 x 50 dots to 999 x 999 dots Helvetica, 10 Font Variations
<b>AGFA RASTER FONTS</b>	
A Font	CG Times, 8 to 72 pt.
B Font	CG Triumvirate, 8 to 72 pt.
<b>DOWNLOADABLE FONTS</b>	
	N/A
<b>CHARACTER CONTROL</b>	
	Expansion up to 12 x in either the X or Y coordinates. Character Pitch Control Line Space Control Journal Print Facility 0, 90, 180, and 270 Degree Rotation

<b>BARCODE CAPABILITIES</b>	
Linear Bar Codes	UPC A/E JAN 8/13 EAN 8/13 Code 39 Code 93 Code 128 Interleaved 2 of 5 Industrial 2 of 5 Matrix 2 of 5 Bookland NW-7 MSI POSTNET UCC/EAN 128 NW-7 (Codabar)
Two Dimensional	QR Code Data Matrix Maxi Code PDF417 Synthetic Symbol
Ratios	1:2, 1:3, 2:5, User definable bar widths
Bar Height	4 to 999 dots, User programmable
Rotation	0, 90, 180, and 270 Degrees
Sequential Numbering	Sequential numbering of both numerics and bar codes
Expansion Ratio of Character	Height: 1-12 times, Width: 1-12 times
Graphics	Full dot addressable graphics, SATO Hex/Binary, BMP or PCX formats
Form Overlay	Form overlay for high-speed editing of complex formats

# 3

## **INSTALLATION**

- **Unpacking & Parts Identification**
- **Printer Installation**
- **Operational Mode Selection**
- **Interface Selection**
- **Accessories Installation**



## UNPACKING & PARTS IDENTIFICATION

---

Unpack the printer as directed in the following procedure.

- 1 Place the shipping container (box) upright on a solid, flat surface.
- 2 Open the box, remove any loose items and the first layer of packing material.
- 3 Carefully lift the printer and accessories from the box and place them on a solid flat surface.
- 4 Remove the plastic covers from the packed items and visually inspect for physical damage.
- 5 Ensure all components are present as dictated on the Packing List.
- 6 Report damaged property.

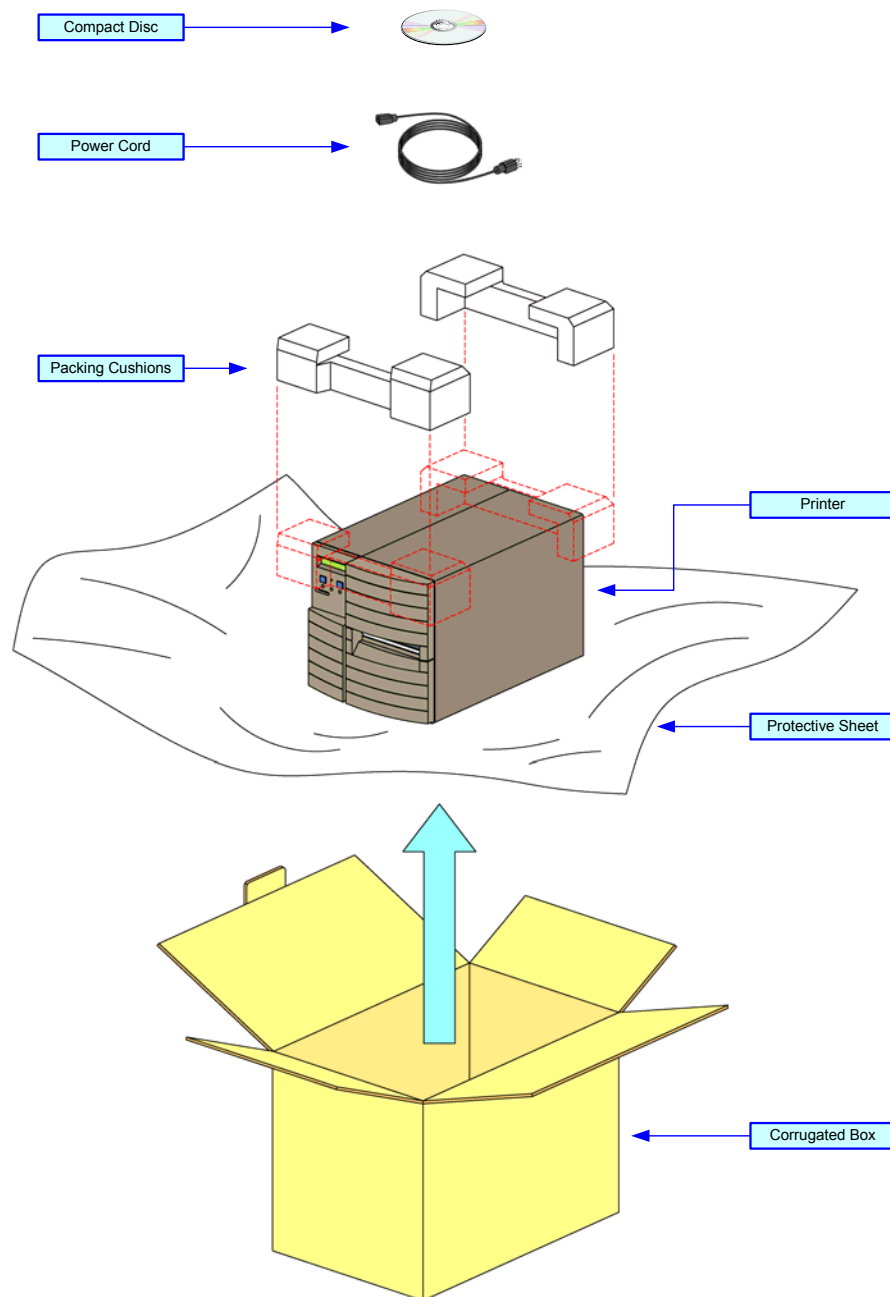

Figure 3-1, Unpacking & Parts Identification

## PRINTER INSTALLATION

This chapter provides guidance on how to station, connect, and load the printer once unpacked. Following printer setup, proceed to the next chapter for information on interface selection.

### SITE LOCATION

- Stationed on a solid flat surface.
- Stationed away from hazardous materials.
- Stationed within operational distance of the host based on interface specifications.

### CABLE CONNECTION

The procedure below provides instruction on typical cable connection. The same procedure will apply to others that are not mentioned, but their connectors are also performed from the printer's rear.

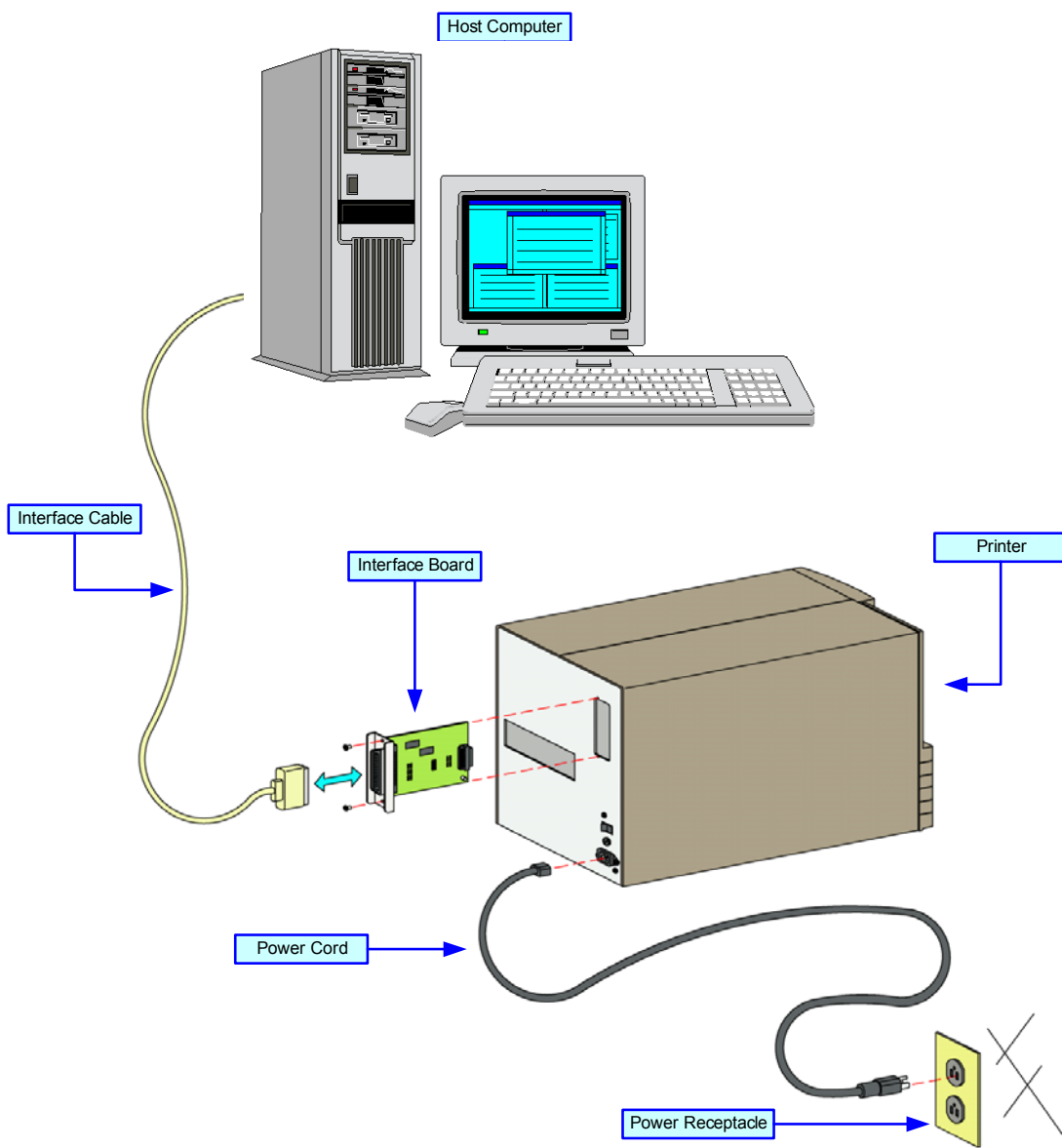

Figure 3-2, Cable Connection

## MEDIA SELECTION

The size and type of the labels or tags to be printed should have been taken into consideration before printer purchase. Ideally, the media width will be equal to, or just narrower than, the print head. Using media that does not cover the print head will allow the platen roller to tread on it and wear it out. The media edge will also wear a groove in the platen roller affecting print quality.

## MEDIA & RIBBON LOADING

There are two general media types that may be loaded and used; rolled and fan-folded. Each of those types may again be defined by whether their print application is direct thermal or thermal transfer. Those factors determine how the media is loaded and if ribbon stock is loaded at all.

Thermal transfer media requires the use of ribbon stock for print application. In such a scenario, it is the ribbon stock (carbon paper) that contains the ink that will be transferred to the media.

Direct thermal media has the ink embedded within and is brought to the surface through heat penetration by print head contact.

Rolled media of standard diameter is loaded within the printer and suspended by the media holder. Larger, non-standard rolled media would be suspended outside the printer at its rear and fed inward. Fan-folded media would also be fed inward from the rear but is stacked as opposed to suspended.

Refer to Figures 3-3a and 3-3b for proper media routing relative to the type to be used. If that to be used is direct thermal, ignore the ribbon stock in the figures and do not load that.

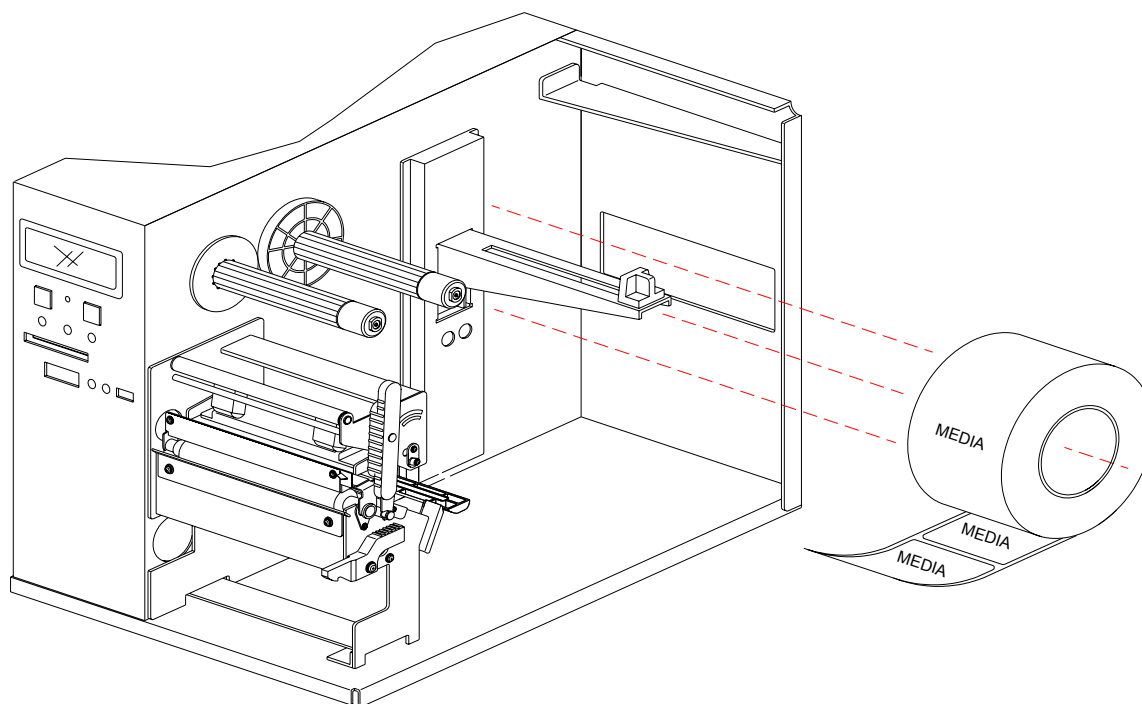

Figure 3-3a, Rolled Media Loading

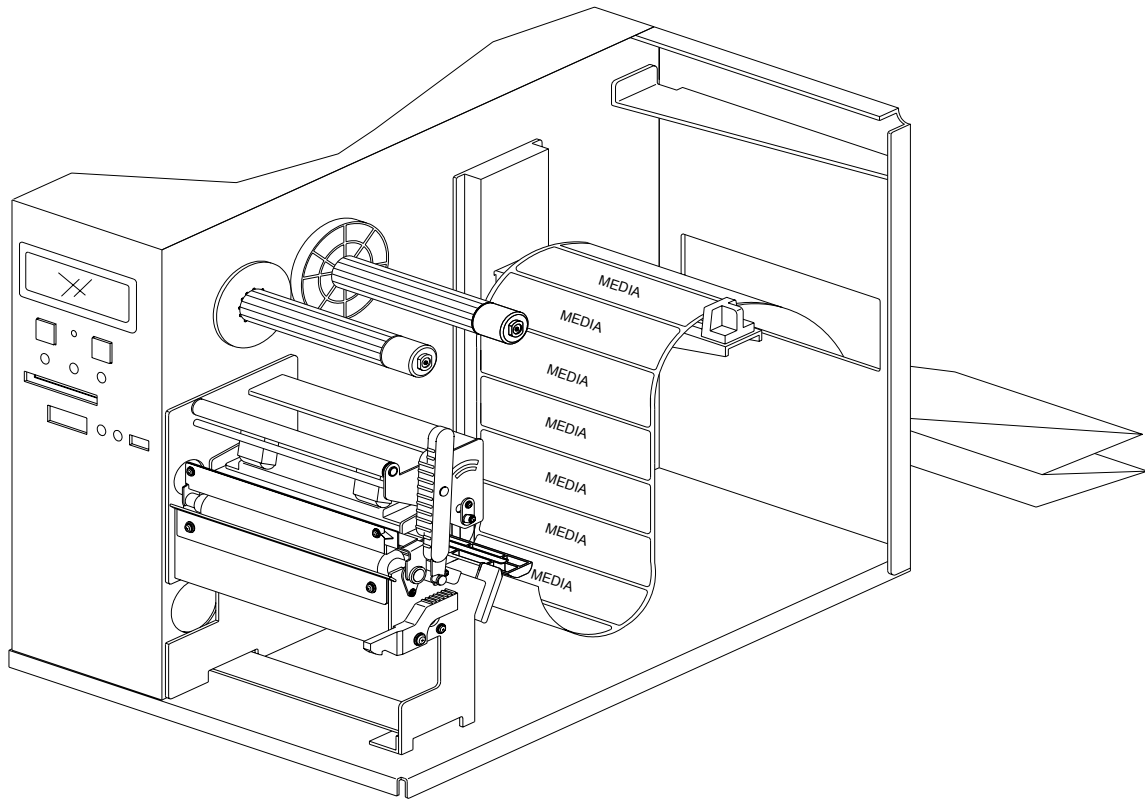

Figure 3-3b, Fan-fold Media Loading

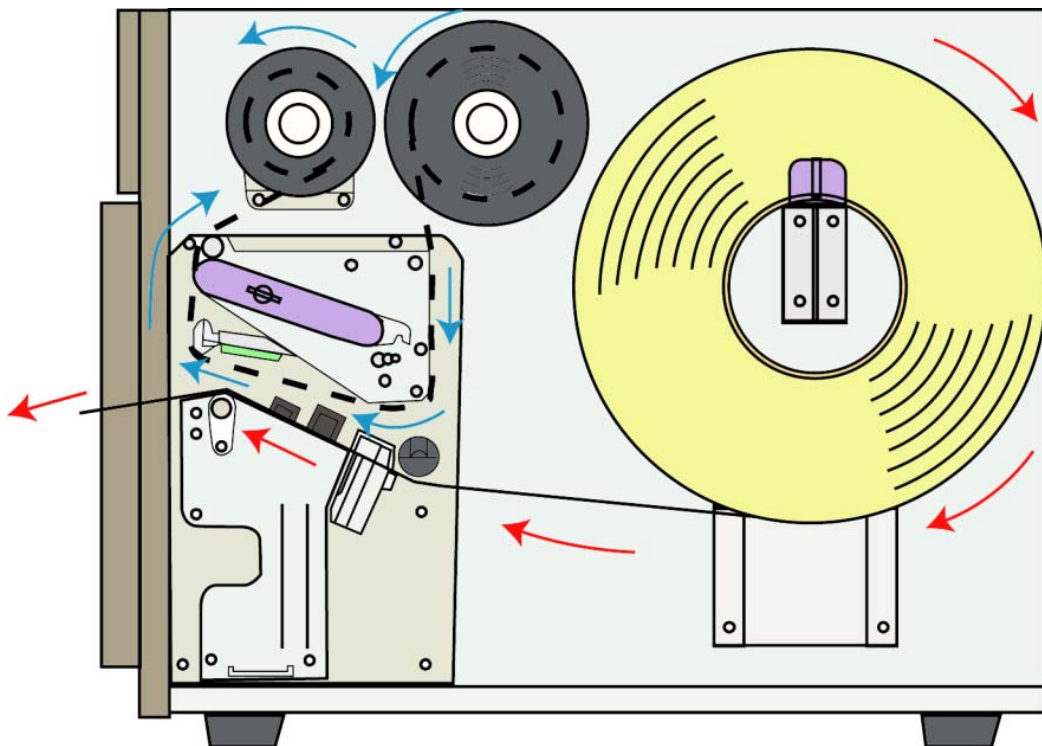

Figure 3-3c, Ribbon Loading

## OPERATIONAL MODE SELECTION

---

There are two modes of printer operation; Dispense and Continuous. The difference between the two is the way that the label and paper backing is ejected. Before printer configuration, one must determine which mode will be used. This chapter identifies the functional differences between the two.

### TEAR-OFF MODE

With this method of operation, after printing, the printer feeds the first (outermost) label so that it is fully extended out of the printer's front for dispensing. Printing of the next label will not begin until the prior printed label has been removed. This mode of operation is specifically suited for immediate application at the time of print.

Upon removal of the prior printed label, the printer repositions the media so that the next label in line may be printed, then prints. The before-mentioned cycle, repeats for each consecutive label.

Printer configuration for the backfeed function may be found in the Advanced Mode of the Configuration unit in this manual. Refer to the Table of Contents for the page number.

### CONTINUOUS MODE

With this mode of operation, the media remains in position for printing at all times. To do so, means that the previous printed label is only available for removal when one to four additional labels have been printed (quantity is depended on label size). This mode of operation is specifically suited for printing bulk quantities to be applied later.

Printer configuration for the Continuous mode of operation may be found in the Advanced Mode of the Configuration unit in this manual. Refer to the Table of Contents for the page number.

**ATTENTION:** Refer to the Printer Configuration unit of this manual to program the printer's internal memory to suit individual needs using the integrated menu options. Refer to the Programming Reference document to remotely program the printer's features and functions through a host system.

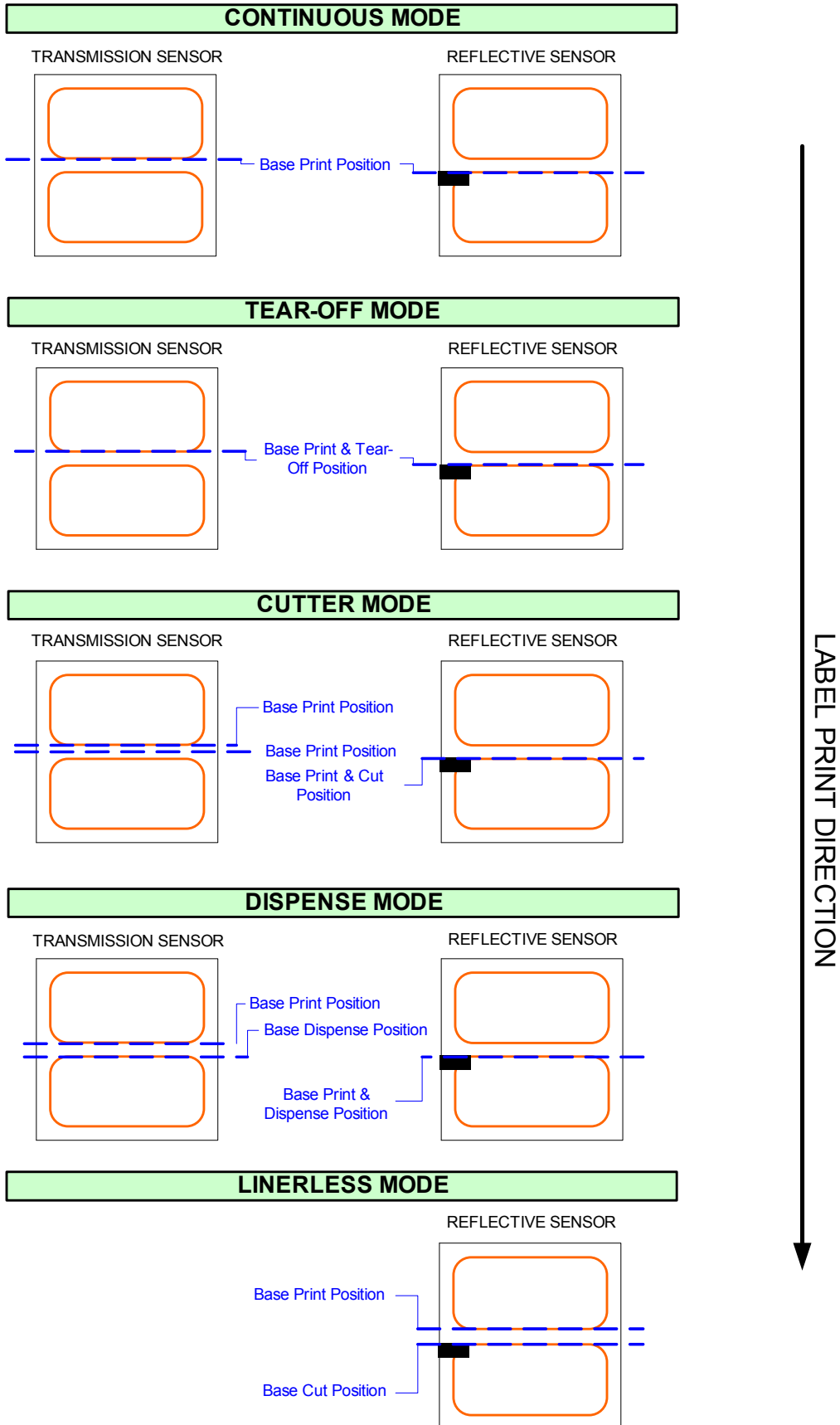

Figure 3-4, Label Reference Position

## INTERFACE SELECTION

This unit presents the printer interface types and their specifications. These specifications include detailed information to assist in the selection of the most appropriate method for the printer to interface with the host. The five acceptable interface methods are:

- RS232C High-Speed Serial
- IEEE1284 Parallel
- Universal Serial Bus (USB)
- Local Area network (LAN) Ethernet
- 802.11b Wireless

Following the selection of the desired interface, proceed to the next unit for instructions on how to Configure the printer for that interface type.

**WARNING: NEVER CONNECT OR DISCONNECT INTERFACE CABLES (OR USE A SWITCH BOX) WITH POWER APPLIED TO EITHER THE HOST OR THE PRINTER. THIS MAY CAUSE DAMAGE TO THE INTERFACE CIRCUITRY IN THE PRINTER/HOST AND IS NOT COVERED BY WARRANTY.**

**NOTE:** Some hosts monitor the Request-To-Send (RTS) signal (pin 4 of 25) to determine if the printer is ready to receive data. Since the printer does not generate this signal, the RTS line must be held true (high) in order to allow communication. This can be performed by connecting the RTS pin to the Clear-To-Send (CTS) signal (pin 5 of 25).

**NOTE:** If assistance is required on the physical installation of the interface, refer to the Accessories Installation unit for guidance.

### RS232C HIGH-SPEED SERIAL INTERFACE

This High Speed Serial Interface is a Plug-In Interface Module that can be installed in the printer by the user.

INTERFACE SPECIFICATIONS	
Asynchronous ASCII	Half-duplex communication Bi-Directional Communication
Data Transmission Rate	9600, 19200, 38400, 57600 bps
Transmission Form	Start, b1, b2, b3, b4, b5, b6, b7, b8, Stop (b8 will be omitted if using 7 bit oriented)
Data Length	7 or 8 bit (selectable)
Stop Bit	1 or 2 bit (selectable)
Parity Bit	ODD, EVEN, NONE (selectable)
Codes Used	ASC II Character Codes: 7 bits, Graphics: 8 bits
Control Codes	STX (02H), ETX (03H), ACK (06H), NAK (15H)
Connector (Printer Side)	DB-25S Male (equivalent)
Cable Connector	DB-25P Female (equivalent)
Cable Length	5 meters (50ft) or less.
Signal Levels	High = +5V to +12V, Low = -5V to -12V
Protocol	Ready/Busy, X-On/X-Off, Protocol for Driver, Status4 (Bi-Com)

DIPSWITCH SETTINGS				
SWITCH	COMPONENT	SETTINGS		
1	Data Bit	ON		7 Bits
		OFF		8 Bits
2 & 3	Parity	2	3	
		ON	ON	Reserved
		ON	OFF	ODD
		OFF	ON	EVEN
		OFF	OFF	NONE
4	Stop Bit	ON		2 Bits
		OFF		1 Bit
5 & 6	Baud Rate	5	6	
		ON	ON	57600 bps
		ON	OFF	38400 bps
		OFF	ON	19200 bps
		OFF	OFF	9600 bps
7 & 8	Protocol	7	8	
		ON	ON	Reserved: Status2 & 3 (when compatible mode is OFF)
		ON	OFF	Protocol for Driver, Status5
		OFF	ON	X-ON/X-OFF
		OFF	OFF	Ready/Busy

READY/BUSY INTERFACE SIGNALS		
PIN	DIRECTION	SIGNAL DEFINITION
1	Reference	FG (Frame Ground)
2	To Host	TD (Transmit Data) - Data from the printer to the host computer. Sends X-On/X-Off characters or status data (bi-directional protocols).
3	To Printer	RD (Receive Data) - Data to the printer from the host computer.
4	To Host	RTS (Request to Send) - Used with Ready/Busy flow control to indicate an error condition. RTS is high and remains high unless the print head is open (in this case, RTS would return to the high state after the print head is closed and the printer is placed back on-line) or an error condition occurs during printing (e.g., ribbon out, label out).
5	To Printer	CTS (Clear to Send) - When this line is high, the printer assumes that data is ready to be transmitted. The printer will not receive data when this line is low. If this line is not being used, it should be tied high (to pin 4).
6	To Printer	DSR (Data Set Ready) - When this line is high, the printer will be ready to receive data. This line must be high before data is transmitted. If this line is not being used, it should be tied high (to pin 20).
7	Reference	SG (Signal Ground)
20	To Host	DTR (Data Terminally Ready) - This signal applies to Ready/Busy flow control. The printer is ready to receive data when this pin is high. It goes low when the printer is off-line, either manually or due to an error condition, and while printing in the single job buffer mode. It will also go low when the data in the buffer reaches the buffer near full level.



READY/BUSY CABLE REQUIREMENTS					
DB9	DB25	HOST	DIRECTION	DB25	PRINTER
1	1	FG (Frame Ground)	Bi-Directional	1	FG (Frame Ground)
2	3	RD (Receive Data)	To Host	2	TD (Transmit Data)
3	2	TD (Transmit Data)	To Printer	3	RD (Receive Data)
8	5	CTS (Clear To Send)	To Printer DB9-6	4	RTS (Request To Send)
4	20	DTR (Data Terminal Ready)	To Printer DB9-4	5	DSR (Data Set Ready)
6	6	DSR* (Data Set Ready)	To Host	6	DTR (Data Terminal Ready)
5	7	SG (Signal Ground)	Bi-Directional	7	SG (Signal Ground)

\* This connection at the host side of the interface would depend upon the pin that is being used as the Ready/Busy signal by the driving software. Typically, on a PC, it would be either CTS (pin5) or DSR (pin 6) on a DB-25 connector.

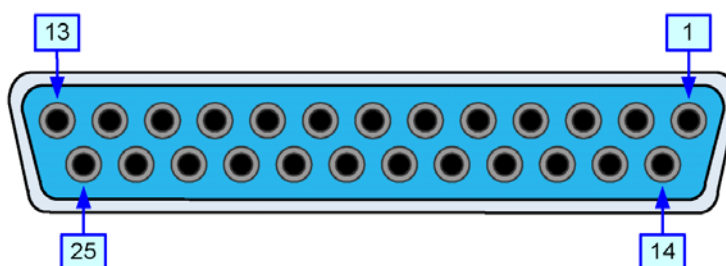

Figure 3-5, Serial Connector Pin Assignments

X-ON/X-OFF CABLE REQUIREMENTS					
Communicates with the host to determine if the printer is ready to receive data by sending "XON" (HEX 11H) or "XOFF" (HEX 13H) code to the TD line. The single and multiple item buffers are switchable in the Interface Mode of the printer.					
DB9	DB25	HOST	DIRECTION	DB25	PRINTER
1	1	FG (Frame Ground)	Bi-Directional	1	FG (Frame Ground)
2	3	RD (Receive Data)	To Host	2	TD (Transmit Data)
3	2	TD (Transmit Data)	To Printer	3	RD (Receive Data)
5	7	SG (Signal Ground)	Bi-Directional	7	SG (Signal Ground)

NOTE: Depending on the host used, it may be required to loop CS and RS (maintaining at high-level) on the host side. For more information, refer to the host computer documentation.

NOTE: Refer to the Charts & Diagrams unit of this manual to view timing charts for Ready/Busy and X-ON/X-OFF.

## IEEE1284 PARALLEL INTERFACE

The parallel interface is a plug-in module that can be installed by the user and conforms to IEEE1284 specifications. It automatically detects the IEEE1284 signals and operates in the high speed mode. If the IEEE1284 signals are not detected, it will operate in the slower standard Centronics mode. For this reason, an interface cable and host interface conforming to the IEEE1284 specification must be present to fully utilize the speed capabilities. This interface also operates bi-directionally and can report the status of the printer back to the host.

SPECIFICATIONS	
Printer Connector	AMP 57-40360 DDK (or equivalent)
Cable Connector	AMP 57-30360 DDK (or equivalent)
Cable	1.5 meter or less
Signal Level	High = +2.4V to +5.0V, Low = 0V to -0.4V
Data Stream	<ESC>A . . Job#1 . . <ESC>Z<ESC>A . . Job#n . . <ESC>Z

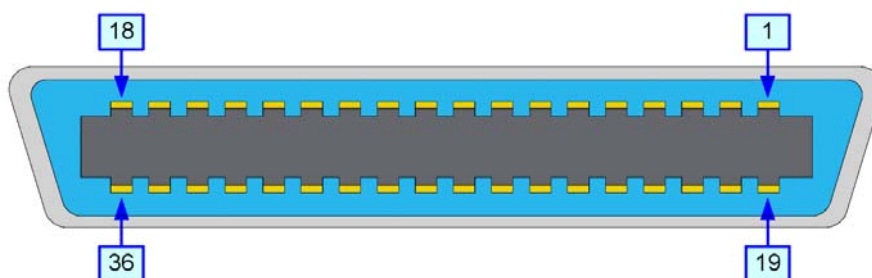

Figure 3-6, Parallel Connector Pin Assignments

PIN ASSIGNMENTS					
PIN	SIGNAL	DIRECTION	PIN	SIGNAL	DIRECTION
1	Strobe	To Printer	19	Strobe Return	Reference
2	Data 1	To Printer	20	Data 1 Return	Reference
3	Data 2	To Printer	21	Data 2 Return	Reference
4	Data 3	To Printer	22	Data 3 Return	Reference
5	Data 4	To Printer	23	Data 4 Return	Reference
6	Data 5	To Printer	24	Data 5 Return	Reference
7	Data 6	To Printer	25	Data 6 Return	Reference
8	Data 7	To Printer	26	Data 7 Return	Reference
9	Data 8	To Printer	27	Data 8 Return	Reference
10	ACK	To Host	28	ACK Return	Reference
11	Busy	To Host	29	Busy Return	Reference
12	Ptr Error	To Host	30	PE Return	Reference
13	Select	To Host	31	INIT	From Host
14	AutoFD <sub>1</sub>	To Host	32	Fault	To Host
15	Not Used		33	Not Used	
16	Logic Gnd		34	Not Used	
17	FG	Frame Gnd	35	Not Used	
18	+5V (z=24k ohm)	To Host	36	SelectIn <sub>1</sub>	From Host

1 Signals required for ieee 1284 mode.

## UNIVERSAL SERIAL BUS (USB)

The Universal Serial Bus (USB) interface is a Plug-In Interface Module that can be installed by the user. It requires a driver (shipped with each printer that has the interface installed) that must be loaded onto the PC and configured to support USB peripherals using Windows 2000 or above. Details for loading the USB driver are contained in the USB Interface Manual that is shipped with each printer with a USB Optional interface installed. Up to 127 devices may be connected to a USB port using powered hubs.

**ATTENTION:** This Interface type is not compatible with Windows 98 or Windows Me.

SPECIFICATIONS	
Printer Connector	USB Type B Plug
Cable	10 feet (3 m) maximum
Host	Windows 2000 or above with USB Port
Power Supply	BUS Power through cable
Power Consumption	+5 V at 80 ma

## LOCAL AREA NETWORK (LAN) ETHERNET

A Local Area Network (LAN) interface is an optional Plug-In Interface Module that can be installed by the user. It requires a driver shipped with each printer that has the interface installed. The driver that must be loaded onto the host computer and configured to run one of the supported network protocols using a 10Base-T or 100Base-TX LAN connection. Details for loading the LAN driver are contained in the LAN Interface Manual that is shipped with each printer with a LAN Optional interface installed.

SPECIFICATIONS	
Connector	RJ-45 Receptacle
Cable	10/100BaseT Category 5
Cable Length	100 meters or less
Power Supply	Powered from printer
Protocol	Status3 return Protocol for Driver (cyclic response mode) Protocol for Driver (ENQ response mode) Status5 return
IP Address	0.0.0.0 to 255.255.255.255
Subnet Mask	0.0.0.0 to 255.255.255.255
Gateway Address	0.0.0.0 to 255.255.255.255

DIPSWITCH SETTINGS	
SWITCH	SETTING
1	Reserved (setup prohibited).
2	LAN board EEPROM initialization (configuration).
3	Print configuration details on a label.
4	Print a self-diagnosis of the board onto a label.

<b>SOFTWARE SPECIFICATIONS</b>	
Corresponding Protocol	TCP/IP
Network Layer	ARP, RARP, IP, ICMP
Session Layer	TCP, UDP
Application Layer	LPD, FTP, TELNET, BOOTP, DHCP
<i>NOTE: Print data can be sent by LPR and FTP of TCP/IP and dedicated socket protocol. Printer status is obtainable by dedicated socket protocol.</i>	
<i>NOTE: In the TCP/IP protocol environment, LPD and FTP are provided for printing; TELNET for variable setup; ARP, RARP, and BOOTP/DHCP for address setup.</i>	
<i>LPD protocol complies with RFC1179 and handles the list of logical printer name as queue name such as lp, sjis, euc. In addition, a banner page can be printed by a proper setup.</i>	
<i>When sending the job by LPR, the transmission order of data file/control file within the job will not affect print operation. In addition, if the banner page is specified, it will be added to each data file. Job deletion by LPR is not available.</i>	
<i>FTP protocol complies with RFC959 and handles the list of logical printer name as a transfer directory. File transfer to this directory executes print operation. It is possible to specify ASCII(A), Binary(I) and TENEX(L8) as transfer mode - although the mode difference is dependent on the client. A banner page may be printed with a proper setup.</i>	
<i>TELNET Complies with RFC854. This operation consists of interactive menu form and enables change and reference of internal setup, and to display status. To change the setup, enter "root" user and password at the time of login. Default of root password is set as null (linefeed only).</i>	

<b>ACCESSORY (EXT) CONNECTOR PIN ASSIGNMENTS</b>			
<b>DB-9</b>	<b>14 PIN</b>	<b>DIRECTION</b>	<b>SIGNAL DEFINITION</b>
<b>1</b>	<b>13</b>	To Host	Vcc +/- 5V
<b>2</b>	<b>10</b>	To Host	Ribbon Near End - Goes high when the amount of ribbon on the supply spindle is approximately 46 feet (14m). The output will be low when the ribbon is completely out.
<b>3</b>	<b>4</b>	To Host	Error - Goes low when the printer detects an error condition.
<b>4</b>	<b>7</b>	To Printer	Reprint - Prints a duplicate of the last label of a print job when this signal is received.
<b>5</b>	<b>5</b>	To Printer	Print Start - Prints a single label when this pin is pulled to ground. This signal must be enabled to function by placing dipswitch DSW3-5 to the OFF position.
<b>6</b>	<b>6</b>	To Host	End Print - Is used to drive an applicator or other external device requiring synchronization with the print cycle. Four types of output signals may be chosen by using dipswitches DSW3-6 and DSW3-7.
<b>7</b>	<b>1</b>	To Host	Label Out - Goes low (0V) when a label error exists.
<b>8</b>	<b>3</b>	To Host	Ribbon Out - Goes low (0V) when ribbon supply is out.
<b>9</b>	<b>2</b>	Reference	Signal Ground.
	<b>8</b>	To Printer	Isolated Power Source - for signal input.
	<b>9</b>	To Host	Mode 1: High voltage on LCD is selected = online, print job waiting. Mode 2: High voltage on LCD is selected = online. Goes low (0V) when offline.
	<b>11</b>		Reserved.
	<b>12</b>	To Host	+24V +/- 10% @ 2A - Power for external devices.
	<b>14</b>		Frame Ground
<b>NOTE:</b> The signals on pins 1, 3, 4, 6, 9, and 10 each have an open collector output. These pins normally measure +.07V maximum when a true condition exists. If a false condition occurs, the voltage will drop to 0V. To achieve a signal level of +5V, you must add a 330 ohm, 1/4 watt, pull-up resistor between the open collector output pin and Vcc (pin 13) as illustrated. This will provide a signal level of +5V for a true condition and 0V when a false condition exists. The maximum voltage that can be applied to these pins is +50V and the maximum current they can sink is 500 milliamps.			

## 802.11G WIRELESS

The wireless print server provides easy printer interface with 802.11G Wi-Fi compliant networks free of wired connections. Each printer is shipped with an integrated driver and interface installed. The driver must be loaded onto the host computer and configured to run one of the supported protocols.

SPECIFICATIONS	
Variable Data Rates	54, 11, 5.5, 2 and 1 Mbps
Frequency Band	2.4 GHz ISM Band
Wired Equivalent Privacy	128 bit, 64 bit (compatible with 40bit), WPA, none
Sensitivity	(typ, AAWGN, 8E-2 PER): -91dBm at 1Mbps, -88dBm at 2 Mdps, -87dBm at 5.5Mbps, -84dBm at 11Mbps.
Range	100m indoors, 300m outdoors
Protocols	TCP/IP, IPX/SPX, Direct Mode IPX/IP, DLC/LLC, NetBEUI, NetBIOS/IP
Protocol	Status3 return Protocol for Driver (cyclic response mode) Protocol for Driver (ENQ response mode) Status5 return
IP Address	0.0.0.0 to 255.255.255.255
Subnet Mask	0.0.0.0 to 255.255.255.255
Gateway Address	0.0.0.0 to 255.255.255.255
Communication Mode	802.11 Ad hoc, Ad hoc, Infrastructure
SSID	Optional alphanumeric character string (up to 32 characters)
Channels	01 to 11

DIPSWITCH SETTINGS	
<p>The dipswitches serve to initialize the configuration saved on the Wireless-LAN board, print the configuration, and make a self-diagnosis. To communicate with the host, set the communication mode by through switches 5 and 6, then set the remaining switches to the OFF position.</p> <p>Print of configuration and self-diagnosis are operable only on the screen after turning on the printer. Ensure all switches are in the OFF position when operating the printer.</p>	
SWITCH	SETTING
1	Reserved for test use only (setup prohibited).
2	LAN board EEPROM initialization (initialize configuration).
3	Print configuration details on a label (diagnostic & configuration).
4	Print a self-diagnosis of the board onto a label (wireless mode).
<p><i>NOTE: The communication mode may be set within the printer's Interface Mode. Go to [Communication] of the Interface Mode to enable setup by either the dipswitches or through the Interface Mode.</i></p>	

LED INDICATOR STATUS			
INDICATOR 1	INDICATOR 2	INDICATOR 3	DESCRIPTION
ON	OFF	OFF	Weak Signal (1-50%)
ON	ON	OFF	Moderate Signal (50-75%)
ON	ON	ON	Strong Signal (75-100%)
OFF	OFF	ON	802.11 Ad hoc
OFF	ON	OFF	Ad hoc

SOFTWARE SPECIFICATIONS	
Corresponding Protocol	TCP/IP
Network Layer	ARP, RARP, IP, ICMP
Session Layer	TCP, UDP
Application Layer	LPD, FTP, TELNET, BOOTP, DHCP
NOTE: Print data can be sent by LPR and FTP of TCP/IP and dedicated socket protocol. Printer status is obtainable by dedicated socket protocol.	
NOTE: In the TCP/IP protocol environment, LPD and FTP are provided for printing; TELNET for variable setup; ARP, RARP, and BOOTP/DHCP for address setup.	
LPD protocol complies with RFC1179 and handles the list of logical printer name as queue name such as lp, sjis, euc. In addition, a banner page can be printed by a proper setup.	
When sending the job by LPR, the transmission order of data file/control file within the job will not affect print operation. In addition, if the banner page is specified, it will be added to each data file. Job deletion by LPR is not available.	
FTP protocol complies with RFC959 and handles the list of logical printer name as a transfer directory. File transfer to this directory executes print operation. It is possible to specify ASCII(A), Binary(I) and TENEX(L8) as transfer mode - although the mode difference is dependent on the client. A banner page may be printed with a proper setup.	
TELNET Complies with RFC854. This operation consists of interactive menu form and enables change and reference of internal setup, and to display status. To change the setup, enter "root" user and password at the time of login. Default of root password is set as null (linefeed only).	

## EXT ACCESSORY PORT

The 14 pin, Centronics type EXT connector provides printer interface with printer accessories with a choice of four different output signals along with various error conditions. A DB-9 to 14 pin Centronics adapter cable is required for interfacing.

READY/BUSY INTERFACE SIGNALS			
DB-9 PIN	14 PIN CENTRONICS	DIRECTION	SIGNAL DEFINITION
1	13	To Host	Vcc +/-5V
2	10	To Host	Ribbon Near End - goes high when the amount of ribbon on the supply spindle is approximately 46 feet (14M). The output is low when the ribbon is completely out.
3	4	To Host	Error - goes low when the printer detects an error condition such as head open or receive buffer is full.
4	7	To Printer	Reprint - a duplicate of the last label in a print job is reprinted when this signal is received.
5	5	To Printer	Print Start - one label will print when this pin is pulled to ground. This signal must be enabled by placing dipswitch DSW3-5 on the control panel to OFF position.
6	6	To Host	End Print - used to drive an applicator or other external device requiring synchronization with the print cycle. Four types of output signals may be chosen using the control panels DSW3-6 and DSW3-7 dipswitches. Refer to the timing charts below.
7	1	To Host	Label Out - goes low (0V) when a label error exists.
8	3	To Host	Ribbon Out - goes low (0V) when ribbon is out.
9	2	Reference	Signal Ground.
	8	To Printer	Isolated Power Source - for signal output.

READY/BUSY INTERFACE SIGNALS			
DB-9 PIN	14 PIN CENTRONICS	DIRECTION	SIGNAL DEFINITION
	9	To Host	When Mode1 on the LCD is selected High Voltage = Online Print Job Waiting. When Mode2 on the LCD is selected High Voltage = Online. This goes low (0V) when the printer is offline.
	11		Reserved.
	12	To Host	+24V +/- 10% @2A - Power for external devices.
	14		Frame Ground

NOTE: The signals on pins 1, 3, 4, and 10 each have an open collector output. These pins normally measure +.07V maximum when a true condition exists. If a false condition occurs, the voltage will drop to 0V. To achieve a signal level of +5V, a 330 ohm, 1/4 watt pull-up resistor between the open collector output pin and Vcc (pin 13) as illustrated. This will provide a signal level of +5V for a true condition and 0V when a false condition exists. The maximum voltage that can be applied to these pins is +50V and the maximum current they can sink is 500 milliamps.

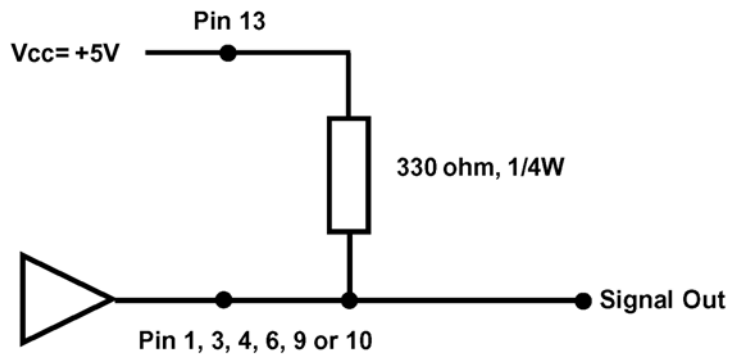

Figure 3-7, Signal Diagram

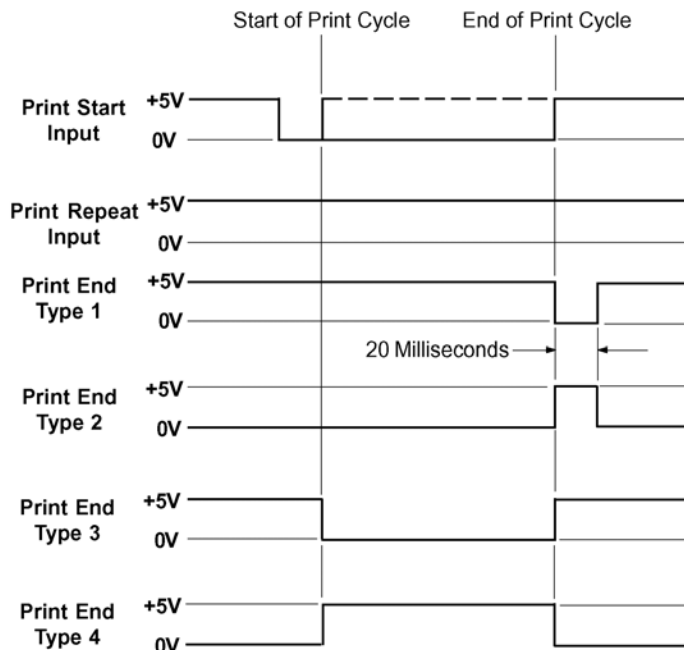

Figure 3-8a, Timing Chart - Standard Operation

Unit 3: Installation

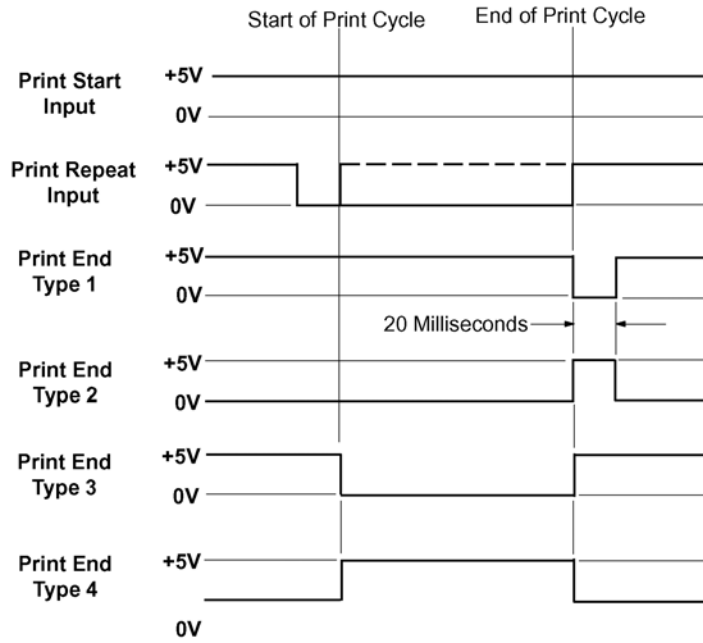

Figure 3-8b, Timing Chart - Repeat Print

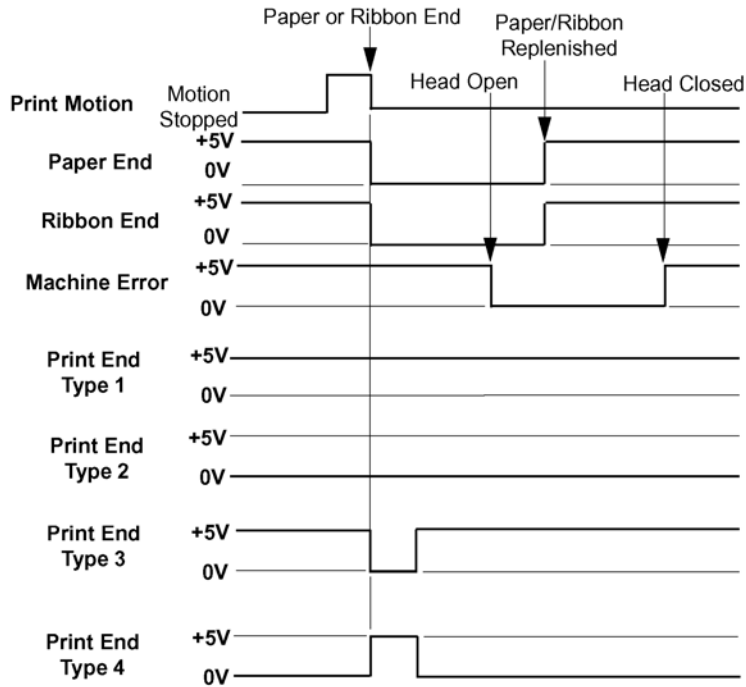

Figure 3-8c, Timing Chart - Error Signals



## ALL INTERFACES

This chapter contains information that is applicable to all interface types offered.

### RECEIVE BUFFER

The data stream is received from the host to the printer one job at a time. This allows the software program to maintain control of the job print queue so that it can move a high priority job in front of ones of lesser importance. A multiple job buffer allows the printer to continuously receive print jobs while compiling and printing other jobs at the same time. It acts much like a Print buffer to maximize the performance of the host and the printer.

The printer receives and prints one job at a time. If a print job exceeds the buffer size, transmission will be rejected by the printer. Flow control protocols to throttle transmission are not used. Error conditions that occur during the Print Data transmission will cause the printer to return a NAK.

### ACK/NAK PROTOCOL

Bi-Directional ACK/NAK protocol is used for error control. In a normal transmission sequence when the transmission is received, the printer will return an ACK (06H) signifying that it was received without a transmission error. After the transmission command structure has been analyzed, a status byte is returned to the host. This status byte informs the host of the validity of the command structure.

If the command structure is error free, the printer proceeds with the print operation. When the print operation is completed, a Printer Status message is returned to the host. If an error was detected during the initial transmission sequence, a NAK (15H) will be returned signalling to the host that the received transmission contained errors and must be resent. If the returned Status byte indicates a command structure error, the error must then be corrected before the print data is resent to the printer.

A valid transmission to the printer must be bounded by an STX/ETX pair, with the STX (02H) signifying the start of the Print Data and ending with an ETX (03H) signifying the end.

### STATUS4 RETURN

This communication protocol is designed for the purpose of monitoring and controlling print data status in the host and featuring various functions.

INTERFACE SIGNALS		
PIN	DIRECTION	SIGNAL DEFINITION
1	Reference	FG (Frame Ground)
2	To Host	TD (Transmit Data) - Data from the printer to the host computer.
3	To Printer	RD (Receive Data) - Data to the printer from the host computer.
7	Reference	SG (Signal Ground)

CABLE REQUIREMENTS					
Depending on the host used, it may need to loop CS and RS (maintaining at high level) on the hose side. For additional information, refer to the host computer documentation.					
DB9	DB25	HOST	DIRECTION	DB25	PRINTER
1	1	FG (Frame Ground)	Bi-Directional	1	FG (Frame Ground)
2	3	RD (Receive Data)	To Host	2	TD (Transmit Data)
3	2	TD (Transmit Data)	To Printer	3	RD (Receive Data)
5	7	SG (Signal Ground)	Bi-Directional	7	SG (Signal Ground)

<b>RECEIVE BUFFER CONTROL</b>	
Causes For Receive Buffer Near Full	Receive buffer near full occurs when the remaining free space of the buffer drops to 0.95MB of 2.95MB capacity or when the remaining free space is available for storing 50 of 500 items in the history buffer.
Release Of Receive Buffer Near Full	Receive buffer near full can be released when the remaining free space rises to 1.95MB or when the remaining free space is available for storing 200 items in the history buffer.

## ACCESSORIES INSTALLATION

---

This chapter covers printer accessory installation procedures that are operator allowed.

### INTERFACE INSTALLATION

The diagram below displays the physical installation of interface hardware. Refer to the Configuration unit of this manual for instructions on printer setup for the interface type chosen.

1. Switch off the printer and disconnect power supply cord.
2. Route interface cable (1, Figure 3-7) from host computer to interface board (2).
3. Insert interface board (2) into printer (4) and secure using two screws (3).
4. Connect interface cable (1).

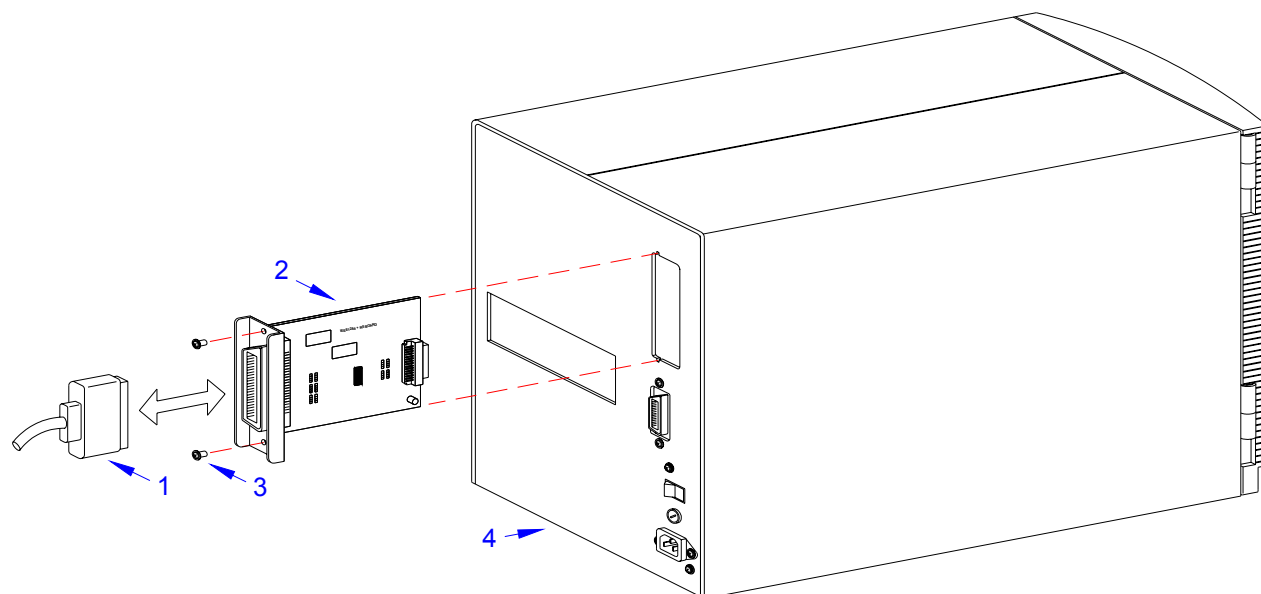

**Figure 3-9, Interface Installation**

# 4

## **PRINTER CONFIGURATION**

- **Printer Configuration**
- **Dipswitch Setting**
- **Configuration Modes**
- **Menu Definition Tables**

## PRINTER CONFIGURATION

---

This unit provides in-depth instruction on printer configuration for operation and for some troubleshooting.

The printer may be configured via the buttons and/or potentiometers located on the printer's operator panel. All of the printer's buttons, switches, and potentiometers are used either singularly, or in conjunction, to perform configuration activities.

Refer to the Control Features chapter of the Introduction unit for identification of specific interface features.

## DIPSWITCH SETTINGS

This chapter identifies the functions of the printer's integrated dipswitches. The dipswitch complex is located on the printer's operator panel and is an integral part of its configuration by enabling/disabling various operational features. Refer to the table below on switch designation and their specific functions.

**ATTENTION:** Each dipswitch must be set for the printer to properly function. Address all eight switches individually, but some may not require change.

**NOTE:** A small, flat tool similar to a screwdriver is required to alter dipswitch position. When changing a switch setting, ensure that it has been moved fully up or down.

**NOTE:** The switches are arranged horizontally, from left to right, and oriented vertically. The ON position is always upward and the OFF position is always downward.

### DSW1 DEFAULT SETTINGS

1-1	1-2	1-3	1-4	1-5	1-6	1-7	1-8
OFF	OFF	OFF	OFF	OFF	OFF	OFF	OFF

### DSW1 CONFIGURATION

1-1	Data Bit	OFF		8 Data Bit
		ON		7 Data Bit
1-2 1-3	Parity	1-2	1-3	Reserved
		ON	ON	Reserved
		ON	OFF	Odd
		OFF	ON	Even
1-4	Stop Bit	OFF		1 Stop Bit
		ON		2 Stop Bit
		1-5	1-6	
		ON	ON	Normal: 2400, High Speed: 57600
1-5 1-6	Baud Rate	ON	OFF	Normal: 4800, High Speed: 38400
		OFF	ON	Normal: 19200, High Speed: 19200
		OFF	OFF	Normal: 9600, High Speed: 9600
		1-7	1-8	
1-7 1-8	Protocol	ON	ON	Status 4
		ON	OFF	Status 3
		OFF	ON	XOn / XOff
		OFF	OFF	Ready / Busy

DSW1 FUNCTION DESCRIPTIONS	
FUNCTION	DESCRIPTION
Data Bit	Sets the printer to receive either 7 or 8 bits of data for each byte transmitted.
Parity	Selects the type of parity used for error detection.
Stop Bit	Selects the number of stop bits to end each byte transmission.
Baud Rate	Select the data rate (bps) for the RS232 port.
Protocol	Selects the flow control and status reporting protocols.

DSW2 DEFAULT SETTINGS							
2-1	2-2	2-3	2-4	2-5	2-6	2-7	2-8
OFF	OFF	OFF	OFF	OFF	OFF	OFF	OFF

DSW2 CONFIGURATION			
DSW1	FUNCTION	SETTING	CONFIGURATION
2-1	Reserved	OFF	
		ON	
2-2	Media Sensor Selection	OFF	Gap Sensor
		ON	Eye-Mark Sensor
2-3	Head Check	OFF	Head Check Disabled
		ON	Head Check Enabled
2-4	Hex Dump	OFF	Hex Dump Disabled.
		ON	Hex Dump Enabled
2-5	Multi-Job Receive Buffer	OFF	Single Job Receive Buffer
		ON	Multi-Job Receive Buffer
2-6	Firmware Download	OFF	Disabled
		ON	Enabled
2-7	Protocol Code	OFF	Standard Protocol Mode
		ON	Non-Standard Protocol Mode
2-8	Operational Mode	OFF	Normal Operation
		ON	Emulation Mode for Original M8400

DSW2 FUNCTION DESCRIPTIONS	
FUNCTION	DESCRIPTION
Media Sensor Selection	Selects between a Gap or Eye-Mark detector.
Head Check	When enabled, will check for malfunctioning head elements.
Hex Dump	Allows hexadecimal printing of all data received to the print buffer.
Multi-Job Receive Buffer	Allows to continuously receive print jobs while compiling and printing other jobs.
Firmware Download	Places printer in mode for downloading software into flash ROM.
Protocol Code	Selects the command codes used for protocol control.
Operational Mode	Normal mode or for original M8400.

DSW3 DEFAULT SETTINGS							
3-1	3-2	3-3	3-4	3-5	3-6	3-7	3-8
OFF	OFF	OFF	OFF	OFF	OFF	OFF	OFF

DSW3 CONFIGURATION				
3-1 3-2	Operating Mode	3-1	3-2	
		OFF	OFF	Batch/Continuous
		OFF	ON	Tear Off
		ON	OFF	Cutter
		ON	ON	Dispenser
3-3	Label Sensor	OFF		Sensor Used
		ON		Sensor Not Used
3-4	Backfeed	OFF		Enabled
		ON		Disabled
3-5	Print Start Signal	OFF		Disabled
		ON		Enabled
3-6 3-7	External Signal Type	3-6	3-7	
		OFF	OFF	Type 4
		OFF	ON	Type 3
		ON	OFF	Type 2
3-8	Repeat Print via Ext Signal	OFF		Disabled
		ON		Enabled

DSW3 FUNCTION DESCRIPTIONS	
FUNCTION	DESCRIPTION
Operating Mode	Batch/Continuous, Tear-Off, Cutter, Dispenser
Label Sensor	Enabled, detects the label's edge and positions it automatically. Disabled, it is under software control.
Back Feed	Enabled, positions the last printed label for dispensing and retracts the media for printing the next.
Print Start Signal	Allows an external device to initiate a label print for synchronization with the applicator. When on, the unit is in the Continuous print mode, Backfeed is disabled and External Signals are ignored.
External Signal	Refer to the Interface Specifications unit for information.
Repeat Print External Signal	Allows an external device to repeat the print sequence.



# CONFIGURATION MODES

This chapter provides an overview of the various configuration modes of the operation menu. All of the configuration activities are performed via the use of the operator panel located on the printer's face. However, many settings may also be controlled via external software commands. In the case of conflict between external software commands and internal software commands (control panel settings) the printer will always use the last valid setting (the default is software commands).

## NORMAL MODE

This mode allows configuration of printing features that are prone to change from job to job. These are some of the most basic and common adjustments of all of the configuration modes.

Refer to the Menu Definition Tables in the following chapter to provide an explanation of each menu screen.

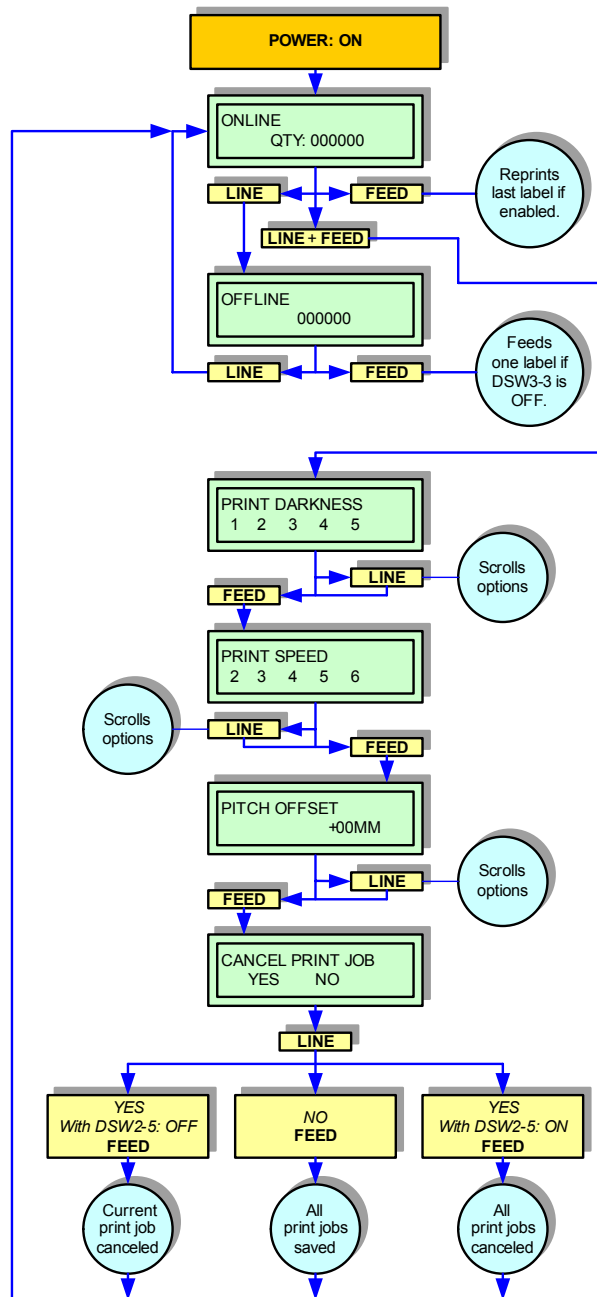

Figure 4-1, Normal Mode

## ADVANCED MODE

The Advanced Mode is provided to make basic printer operational adjustments. Typically, once these adjustments or settings have been made, they will not require additional address unless a new job is downloaded. Use the keys of the printer's operator panel to select and enter the required options.

Refer to the Menu Definition Tables in the following chapter to provide an explanation of each menu screen.

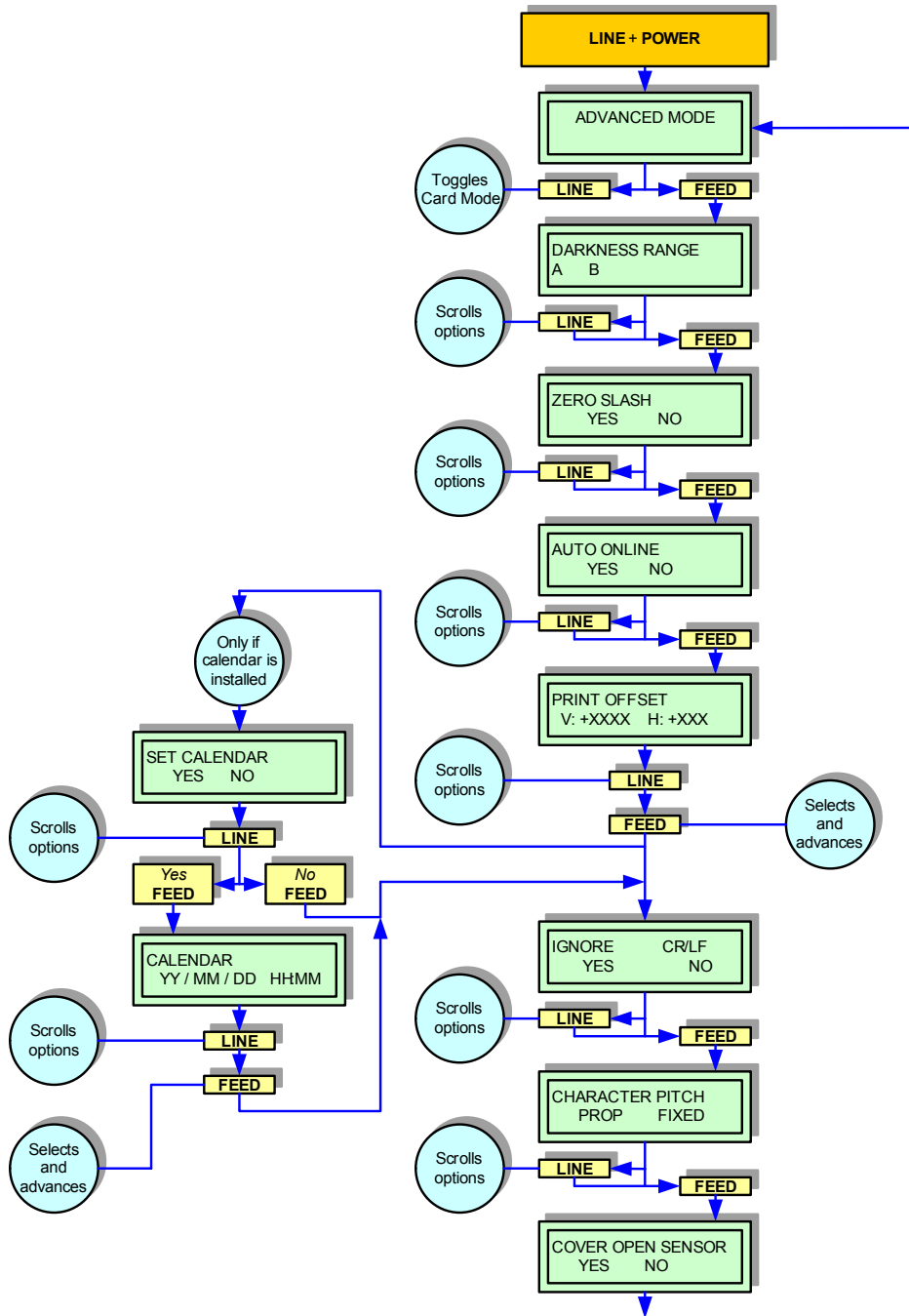

Figure 4-2, Advanced Mode

## USER DOWNLOAD MODE

Allows the operator to download user specific data from a host system. Use the keys of the printer's operator panel to select and enter the required options.

Refer to the Menu Definition Tables in the following chapter to provide an explanation of each menu screen.

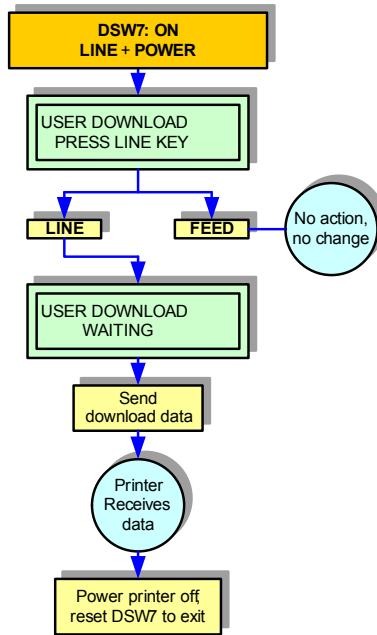

Figure 4-3, User Download Mode

## SERVICE MODE

Allows programming of various dimensional settings, sensor thresholds, and language options. Use the keys of the operator panel to select and enter the required options.

Refer to the Menu Definition Tables in the following chapter to provide an explanation of each menu screen.

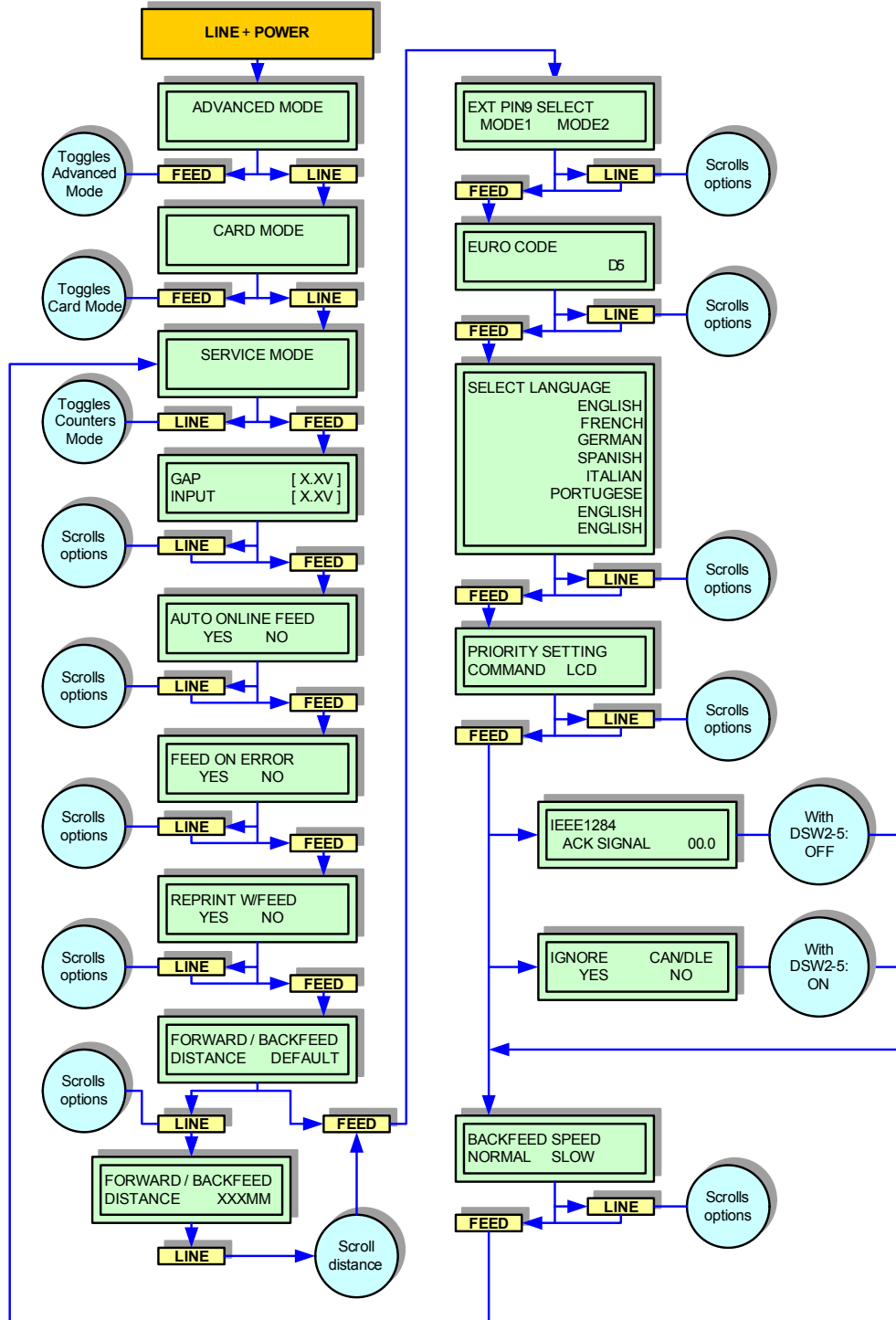

Figure 4-4, Service Mode

### CARD MODE

This mode permits the configuration of an optional memory cartridge. This cartridge, when loaded, provides increased storage capacity for text and graphics. Use the keys of the printer's operator panel to select and enter the required options.

Refer to the Menu Definition Tables in the following chapter to provide an explanation of each menu screen.

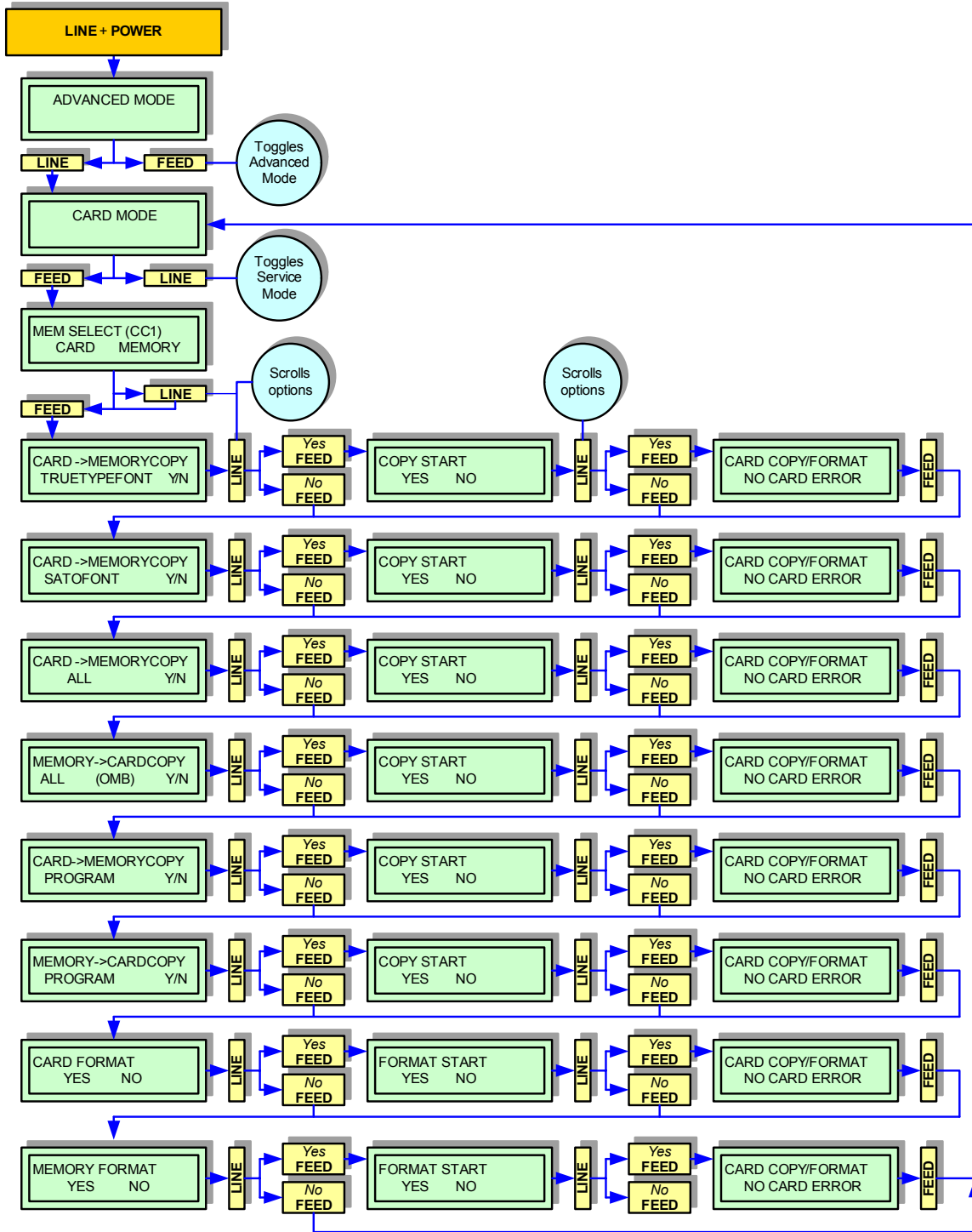

Figure 4-5, Card Mode

## PROTOCOL INITIALIZATION MODE

Allows non-standard protocol code to be returned to the default value. The default value is: STX (7BH), ETX (7DH), ESC (5EH), ENQ (40H), NULL (7EH), CAN (21H), Offline (5DH), EuroCode (D5H).

Use the keys of the printer's operator panel to select and enter the required options. Refer to the Menu Definition Tables in the following chapter to provide an explanation of each menu screen.

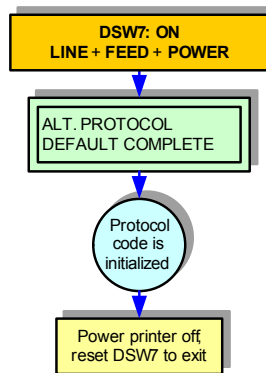

Figure 4-6, Protocol Initialization Mode

## COUNTERS MODE

The printer has integrated counters to measure the accumulative activity of some features. The unit of measure is based on linear meters and includes a print head counter and a life counter. The head counter records the length of the media that has been printed since the print head was installed and should be reset each time the print head is replaced.

The life counter measures the length of media the printer as a whole has printed. This counter would only be reset in case circuitry replacement.

The printer's Counter Mode allows the operator to view the accumulated measurement and also allows the print head counter to be reset to zero.

Use the keys of the printer's operator panel to select and enter the required options. Refer to the Menu Definition Tables in the following chapter to provide an explanation of each menu screen.

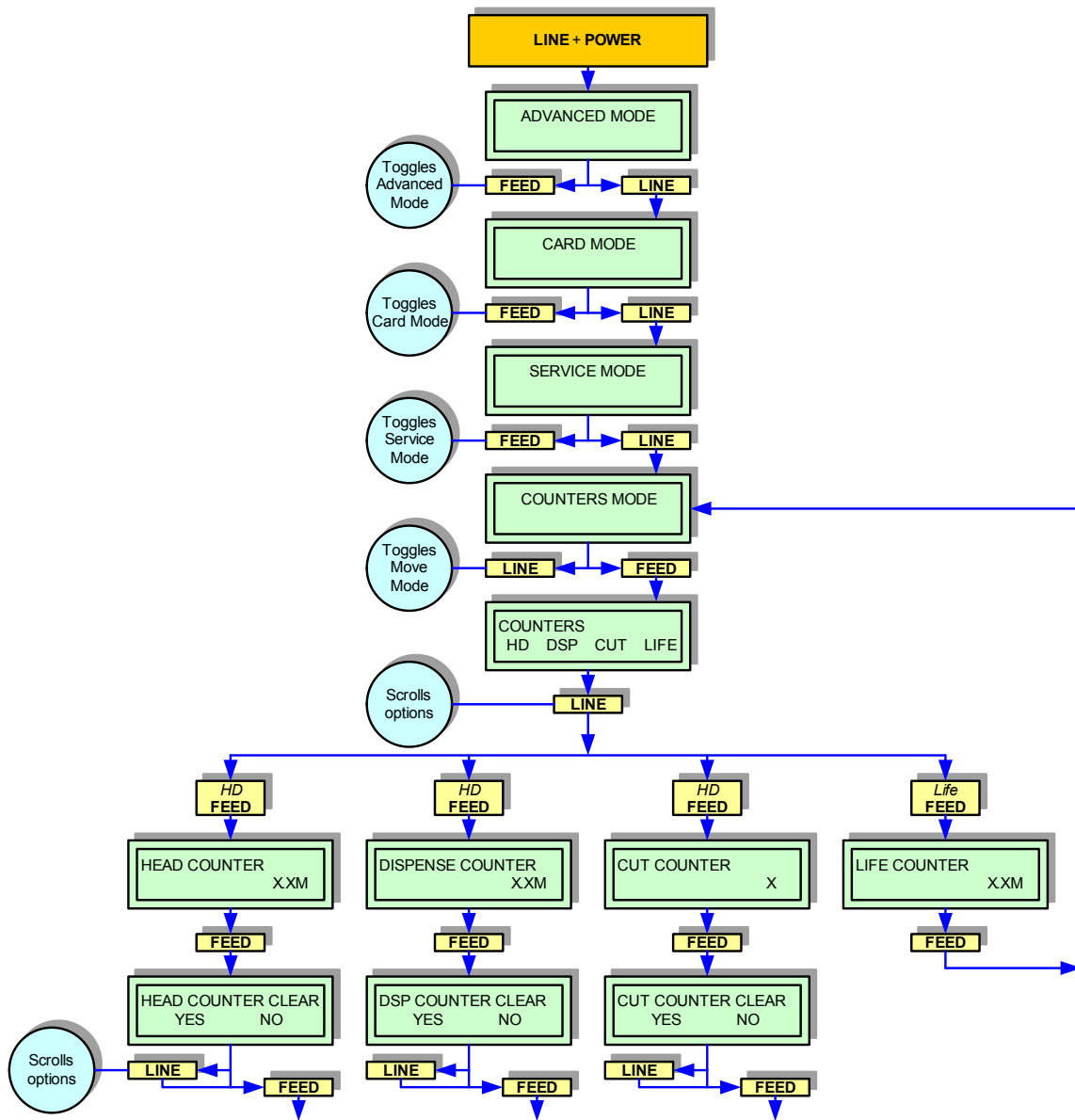

Figure 4-7, Counters Mode

## TEST PRINT MODE

Provides the specific sequence of events required by the operator, the printer, and the printer's software for a test label to be printed. Test labels are designed to identify failures in configuration, adjustments problems, and mechanical defects.

Use the keys of the printer's operator panel to select and enter the required options. Refer to the Menu Definition Tables in the following chapter to provide an explanation of each menu screen.

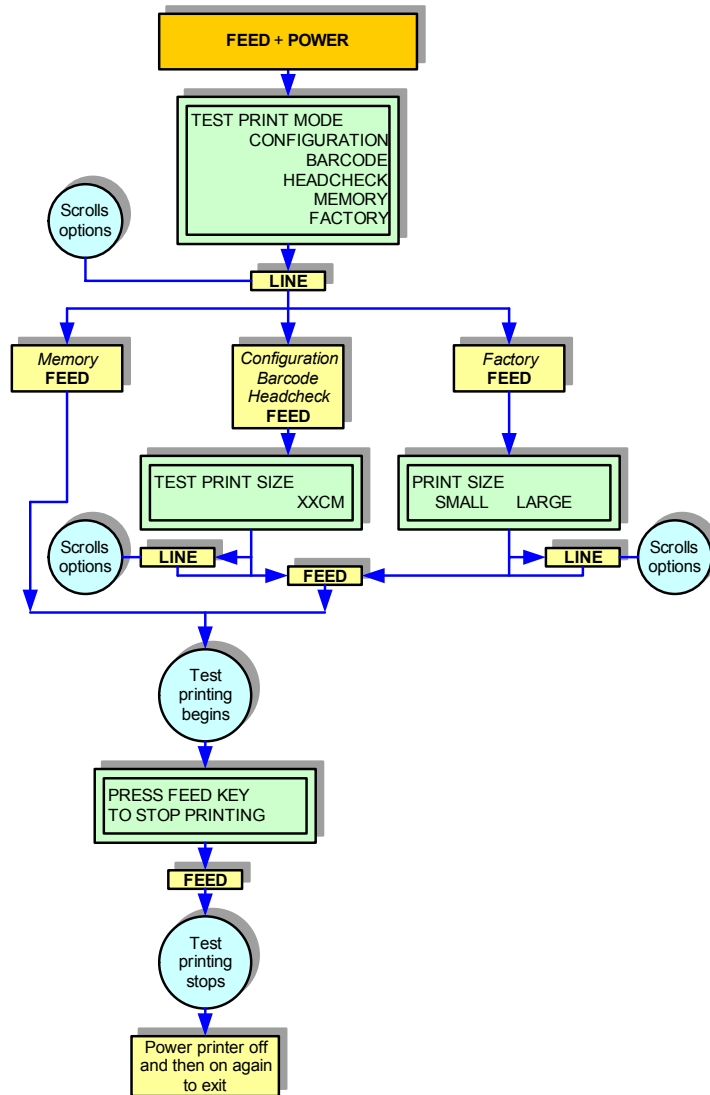

Figure 4-8, Test Print Mode



### BOOT DOWNLOAD MODE

This download mode is used when the Firmware becomes corrupted and the normal download mode is not successful. Allows the program to be downloaded from the host computer.

Figure 5-11 provides the specific sequence of events required by the operator, the printer, and the printer's software. Use the printer's operator panel to select and enter the required options.

Refer to the Menu Definition Tables in the following chapter to provide an explanation of each menu screen.

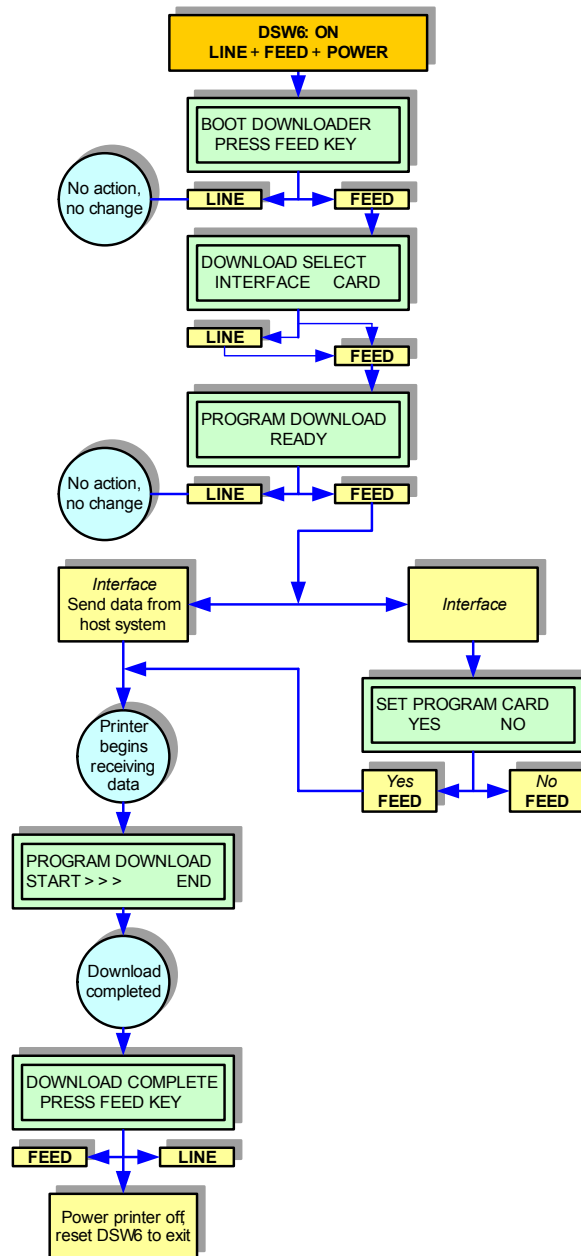

Figure 4-9, Boot Download Mode

### FLASH MEMORY DOWNLOAD MODE

A Flash ROM internally stores/deletes font and custom designed character data. The data is sent from a host system to the printer. Use the printer's operator panel to select and enter the required options.

Refer to the Menu Definition Tables in the following chapter to provide an explanation of each menu screen.

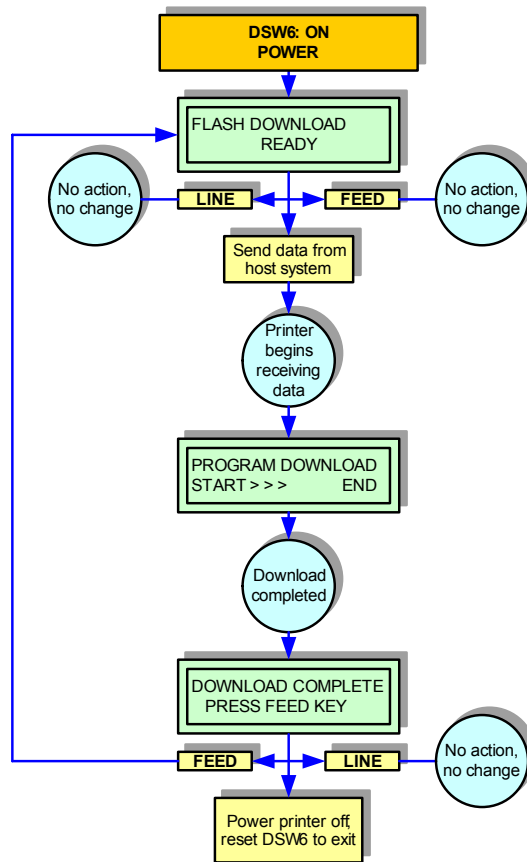

Figure 4-10, Flash Memory Download Mode

## DEFAULT SETTING MODE

The Default Settings Mode allows the operator to return the printer to the configuration state as received from the factory. Use the printer's keys to select and enter the required options.

Refer to the Menu Definition Tables in the following chapter to provide an explanation of each menu screen.

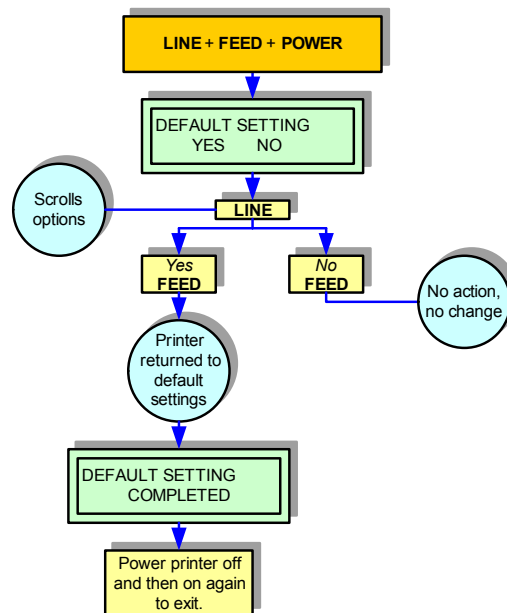

Figure 4-11, Default Setting Mode

## HEX DUMP MODE

The contents of the print buffer and the contents received before it may be examined through the use of the Hex Dump Mode. Each line of the printed data is enumerated in the first column, the second column contains the data in hexadecimal format, and the right column contains the same data in ASCII format.

Use the printer's operator panel to select and enter the required options. Refer to the Menu Definition Tables in the following chapter to provide an explanation of each menu screen.

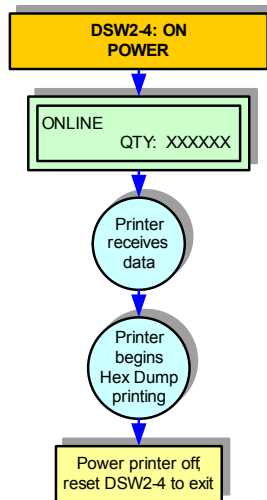

Figure 4-12, Hex Dump Mode

## MAINTENANCE MODE

The Maintenance Mode permits counter reset of various printer components. Use the printer's operator panel to select and enter the required options.

The printer has integrated counters to measure the accumulative activity of some features. The unit of measure is based on linear meters and includes a print head counter and a life counter. The head counter records the length of the media that has been printed since the print head was installed and should be reset each time the print head is replaced.

The life counter measures the length of media the printer as a whole has printed. This counter would only be reset in case circuitry replacement.

The printer's Counter Mode allows the operator to view the accumulated measurement and also allows the print head counter to be reset to zero.

Refer to the Menu Definition Tables in the following chapter to provide an explanation of each menu screen.

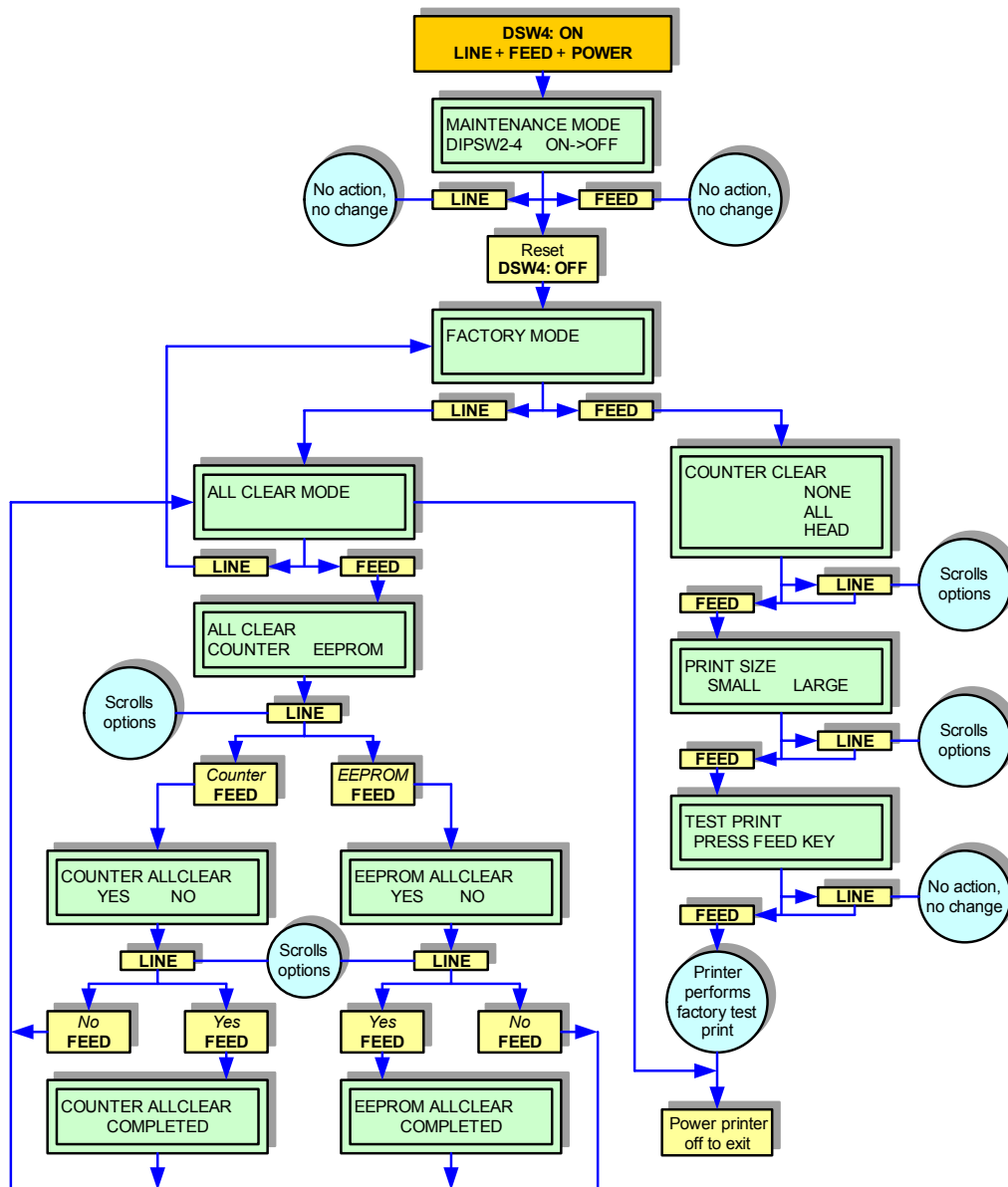

Figure 4-13, Maintenance Mode

## MENU DEFINITION TABLES

NORMAL MODE (TABLE 4-1)	
MENU	DESCRIPTION
<pre> ONLINE   QTY: XXXXXX           </pre>	Displays the printer's operational status. The ONLINE status is displayed on the top line and the label quantity status is on the bottom. The message will be changed to OFFLINE whenever the printer is switched offline by pressing the LINE key. When a print job is received, the quantity line will indicate the number of labels to be printed. As the label job prints, the display status indicates the quantity of labels remaining to be printed.
<pre> OFFLINE   QTY: XXXXXX           </pre>	Displays the printer's operational status. The OFFLINE status is displayed on the top line and the label quantity status is on the bottom. The message will be changed to ONLINE whenever the printer is switched online by pressing the LINE key.
<pre> PRINT DARKNESS  1  2  3  4  5           </pre>	Permits the adjustment of print density. Higher print density equates to darker print images.
<pre> PRINT SPEED  2  3  4  5  6           </pre>	Permits the printer's printing speed to be established based on inches per second (IPS).
<pre> PITCH OFFSET   +00MM           </pre>	<p>The label pitch is the distance from the leading edge (the edge that comes out of the printer first) of a label and the leading edge of the next label. Once the position has been set, it can be fine adjusted using the PITCH potentiometer.</p> <p>Positive (+) digit settings moves the leading edge forward and away from the print head while a negative (-) setting moves the label's leading edge incrementally back into the mechanism.</p>
<pre> CANCEL PRINT JOB   YES  NO           </pre>	Print data that has previously been received, can be cleared. If YES is selected, the print data will be deleted and then the printer will go offline. If the NO option is selected, the printer will go offline without deleting data in buffer.

ADVANCED MODE (TABLE 4-2)	
MENU	DESCRIPTION
<pre> ADVANCED MODE           </pre>	Is the first menu screen of the Advanced Mode. The Advanced Mode is provided to make basic printer operational adjustments. Typically, once these adjustments or settings have been made, they will not require additional address unless a new bob is downloaded.
<pre> DARKNESS RANGE   A  B           </pre>	Allows the darkness (print density) selection of the printed image. Has two selection options.
<pre> ZERO SLASH   YES  NO           </pre>	This menu allows for the printer to be configured to print zeros with or without a diagonal slash through them. This will apply to all font types with the exception of Kanji font.

<b>ADVANCED MODE (TABLE 4-2)</b>	
<b>MENU</b>	<b>DESCRIPTION</b>
<div style="border: 1px solid black; padding: 5px;">           AUTO ONLINE            YES    NO         </div>	The printer can be set to automatically go into the online mode when powered on. Otherwise, the printer starts in the offline state and must be manually placed online before it is ready to print.
<div style="border: 1px solid black; padding: 5px;">           PRINT OFFSET            V: +XXXX H: +XXX         </div>	Print offset refers to the vertical and horizontal shifting of the entire print area relative to the label and the print start position. The movement is incremental by dots in the positive (+) or negative (-) direction. Positive and negative vertical adjustment is toward and away from the print head respectively. Positive and negative horizontal adjustment is to the left and right of the reference point respectively.
<div style="border: 1px solid black; padding: 5px;">           IGNORE      CR/LF            YES        NO         </div>	<p>Determines whether the print data code requires deletion. Hexadecimal graphic data will not be deleted. Select YES to delete all carriage return (CR) and line feed (LF) commands in the data stream - including graphics and 2D barcodes.</p> <p>This feature is primarily used to maintain compatibility with earlier models of SATO printers.</p>
<div style="border: 1px solid black; padding: 5px;">           CHARACTER PITCH            PROP    FIXED         </div>	<p>This setting determines whether each character occupies a designated space (fixed) regardless of the character's width, or if the character's space is representative of its width (proportional). Proportional is contemporarily preferred.</p>
<div style="border: 1px solid black; padding: 5px;">           COVER OPEN SENSOR            YES    NO         </div>	This feature allows the operator to determine if the cover-open sensor is enabled or disabled. If the sensor is enabled, the printer will cease to function if the printer's housing cover is opened during printing.
<div style="border: 1px solid black; padding: 5px;">           SET CALENDAR            YES    NO         </div>	<p>The calendar is an optional feature that allows the date and time to be manually set using the operator panel or through command codes. This screen will not be displayed if the calendar chip (real-time clock) is not installed.</p> <p>This menu allows the operator to choose if the calendar settings are to be altered.</p>
<div style="border: 1px solid black; padding: 5px;">           CALENDAR            00 / 00 / 00 00:00         </div>	This menu screen allows the calendar settings to be altered. The calendar is divided into five sets of two digits. The first two allows for the year to be set, followed by the month, the day, the hour, then the minute.

<b>USER DOWNLOAD MODE (TABLE 4-3)</b>	
<b>MENU</b>	<b>DESCRIPTION</b>
<div style="border: 1px solid black; padding: 5px;">           USER DOWNLOAD            PRESS LINE KEY         </div>	Is the first menu screen of the User Download Mode and provides a prompt to proceed. Pressing the LINE key will place the printer in a condition waiting for the data to be received.
<div style="border: 1px solid black; padding: 5px;">           USER DOWNLOAD            WAITING         </div>	Confirms the printer is on standby for receiving user download data. The downloaded data received from the host shall be written in the main ROM. Entry is not required.

SERVICE MODE (TABLE 4-4)	
MENU	DESCRIPTION
<div style="border: 1px solid black; padding: 5px; width: fit-content;">                     ADVANCED MODE                 </div>	<p>Is the first menu screen of the Advanced Mode. The Advanced Mode is provided to make basic printer operational adjustments. Typically, once these adjustments or settings have been made, they will not require additional address unless a new bob is downloaded.</p> <p>Is only a transitional menu screen to access the Service Mode.</p>
<div style="border: 1px solid black; padding: 5px; width: fit-content;">                     CARD MODE                 </div>	<p>The Card Mode allows the operator to manage or format the expanded memory card. Is only a transitional menu screen to access the Service Mode.</p>
<div style="border: 1px solid black; padding: 5px; width: fit-content;">                     SERVICE MODE                 </div>	<p>The Service Mode allows the programming of various dimensional settings, sensor thresholds, and language options.</p>
<div style="border: 1px solid black; padding: 5px; width: fit-content;">                     GAP INPUT [X.XV]                      INPUT [X.XV]                 </div>	<p>When setting the sensor threshold, the voltage shown on the top line is the measurement using only the media's backing paper placed over the sensor. The lower line displays the measurement with the media and backing paper combined.</p> <p>DSW2-2 determines which sensor will be enabled for use.</p>
<div style="border: 1px solid black; padding: 5px; width: fit-content;">                     AUTO ONLINE FEED                      YES NO                 </div>	<p>Allows it to be determined if the printer will feed a label when it is placed online to ensure proper media placement for printing.</p>
<div style="border: 1px solid black; padding: 5px; width: fit-content;">                     FEED ON ERROR                      YES NO                 </div>	<p>Allows it to be determined if the printer will feed a label when an error condition is cleared.</p>
<div style="border: 1px solid black; padding: 5px; width: fit-content;">                     REPRINT W/FEED                      YES NO                 </div>	<p>Allows it to be determined if the printer will print the last label in memory when the FEED key is pressed in the normal, online mode.</p>
<div style="border: 1px solid black; padding: 5px; width: fit-content;">                     FORWARD / BACKFEED                      DISTANCE DEFAULT                 </div>	<p>Allows the selection of whether to accept the default setting or to set the backfed distance other than the default setting.</p>
<div style="border: 1px solid black; padding: 5px; width: fit-content;">                     FORWARD / BACKFEED                      DISTANCE XXXMM                 </div>	<p>Allows the backfeed distance to be set. If using thermal transfer for printing, set the feed distance less than 30mm to avoid detection of the ribbon end by accident.</p>
<div style="border: 1px solid black; padding: 5px; width: fit-content;">                     EXT PIN9 SELECET                      MODE1 MODE2                 </div>	<p>Allows selection of the conditions that regulates Pin-9 of the EXT connector. MODE1 enables Pin-9 when the printer goes online and a print quantity is displayed. MODE2 enables Pin-9 when the printer goes online without consideration of print quantity.</p>
<div style="border: 1px solid black; padding: 5px; width: fit-content;">                     EURO CODE                      D5                 </div>	<p>Allows the hexadecimal value to be specified for the character replaced with the Euro Character. The default is D5H. ASCII (213)</p>



<b>SERVICE MODE (TABLE 4-4)</b>	
<b>MENU</b>	<b>DESCRIPTION</b>
<div style="border: 1px solid black; padding: 5px; width: fit-content;">                     SELECT LANGUAGE                      ENGLISH                      FRENCH                      GERMAN                      SPANISH                      ITALIAN                      PORTUGUESE                      ENGLISH                      ENGLISH                 </div>	<p>Allows the selection of the character set used by the printer. The world's primary commercial languages are provided as options.</p>
<div style="border: 1px solid black; padding: 5px; width: fit-content;">                     PRIORITY SETTING                      COMMAND LCD                 </div>	<p>Allows the selection of which type of operator programming will take priority precedence. By selecting the COMMAND option, downloaded command codes will be recognized by the printer as most important where conflicting data exists.</p> <p>Selecting LCD, places programming through the operator panel as taking precedence.</p>
<div style="border: 1px solid black; padding: 5px; width: fit-content;">                     IEEE1284                      ACK SIGNAL    XX.X                 </div>	<p>This menu screen allows the pulse width to be set if single-item buffer has been chosen. If single-item buffer has not been chosen, this setting will not have effect.</p>
<div style="border: 1px solid black; padding: 5px; width: fit-content;">                     IGNORE    CAN/DLE                      YES        NO                 </div>	<p>Allows the determination of whether to ignore the CAN and DLE commands used in bi-directional communications. This menu option will only be applicable if multi-item buffer has been chosen.</p>
<div style="border: 1px solid black; padding: 5px; width: fit-content;">                     BACKFEED SPEED                      NORMAL    SLOW                 </div>	<p>Allows of the backfeed movement to be established. Two setting options are available.</p>

<b>CARD MODE (TABLE 4-5)</b>	
<b>MENU</b>	<b>DESCRIPTION</b>
<div style="border: 1px solid black; padding: 5px; width: fit-content;">                     ADVANCED MODE                 </div>	<p>Is the first menu screen of the Advanced Mode. The Advanced Mode is provided to make basic printer operational adjustments. Typically, once these adjustments or settings have been made, they will not require additional address unless a new bob is downloaded.</p> <p>Is only a transitional menu screen for the Service Mode.</p>
<div style="border: 1px solid black; padding: 5px; width: fit-content;">                     CARD MODE                 </div>	<p>Is the first menu screen of the Card Mode and is informational only. The Card Mode allows the operator to manage the expanded memory card.</p>
<div style="border: 1px solid black; padding: 5px; width: fit-content;">                     MEMORY SELECT (CC1)                      CARD    MEMORY                 </div>	<p>Determines the type of optional expanded memory that will be addressed as CC1 in the command stream. The CARD selection specifies the optional PCMCIA card as CC1 and the optional expanded Flash ROM as CC2. The MEMORY selection specifies the optional expanded Flash ROM as CC1 and the optional PCMCIA card as CC2.</p>
<div style="border: 1px solid black; padding: 5px; width: fit-content;">                     CARD -&gt;MEMORY COPY                      TRUETYPEFONT   Y/N                 </div>	<p>Allows the copying of TrueType fonts from the PCMCIA Memory card to the optional Flash ROM.</p>

CARD MODE (TABLE 4-5)	
MENU	DESCRIPTION
CARD ->MEMORY COPY SATOFONT Y/N	Allows the copying of SATO fonts from the PCMCIA Memory card to the optional Flash ROM.
CARD ->MEMORY COPY ALL Y/N	Allows the copying of the entire contents from the PCMCIA Memory Card to the optional internal expanded memory.
MEMORY ->CARD COPY ALL (OMB) Y/N	Allows copying of the entire contents of the optional Expanded Memory to the PCMCIA Memory Card.
CARD ->MEMORY COPY PROGRAM Y/N	Confirms the intent to copy contents from the memory area to the card.
MEMORY ->CARD COPY PROGRAM Y/N	Confirms the intent to copy contents from the card to the memory area.
CARD FORMAT YES NO	Confirms the intent to clear card contents.
MEMORY FORMAT YES NO	Before the internal expanded memory may be used, it must be formatted. This screen allows the determination of whether to format or not based on if it will be utilized.
COPY START YES NO	Allows confirmation of the selection. If NO is selected, the display returns to the previous display.
FORMAT START YES NO	When ready, the operator may choose YES to initiate formatting activity. Selecting NO, returns the operator to the beginning of the Card Mode.
CARD COPY/FORMAT NO CARD ERROR	Displays if an error occurs during the copy process.

PROTOCOL INITIALIZATION MODE (TABLE 4-6)	
MENU	DESCRIPTION
<div style="border: 1px solid black; padding: 5px; width: fit-content;">                     ALT. PROTOCOL DEFAULT COMPLETE                 </div>	Initialization is automatic when the proper keys and switches are activated. This is the only screen that will appear and will indicate that non-standard protocol code to be returned to the default value. The default value is: STX (7BH), ETX (7DH), ESC (5EH), ENQ (40H), NULL (7EH), CAN (21H), Offline (5DH), EuroCode (D5H).

COUNTERS MODE (TABLE 4-7)	
MENU	DESCRIPTION
<div style="border: 1px solid black; padding: 5px; width: fit-content;">                     ADVANCED MODE                 </div>	Is the first menu screen of the Advanced Mode. The Advanced Mode is provided to make basic printer operational adjustments. Typically, once these adjustments or settings have been made, they will not require additional address unless a new bob is downloaded.  Is only a transitional menu screen to access the Counters Mode.
<div style="border: 1px solid black; padding: 5px; width: fit-content;">                     CARD MODE                 </div>	The Card Mode allows the operator to manage or format the expanded memory card. Is only a transitional menu screen to access the Counters Mode.
<div style="border: 1px solid black; padding: 5px; width: fit-content;">                     SERVICE MODE                 </div>	The Service Mode allows the programming of various dimensional settings, sensor thresholds, and language options.  Is only a transitional menu screen to access the Counters Mode.
<div style="border: 1px solid black; padding: 5px; width: fit-content;">                     COUNTERS MODE                 </div>	Is the first menu screen of the Counters Mode. The Counters Mode allows the printers various internal counters to be reset to zero or to view count in meters printed thus far.
<div style="border: 1px solid black; padding: 5px; width: fit-content;">                     COUNTERS HD DSP CUT LIFE                 </div>	Allows the selection of which counter to be viewed to reset.
<div style="border: 1px solid black; padding: 5px; width: fit-content;">                     HEAD COUNTER XX.XM                 </div>	Is an informational screen that provides the printed length of media using the existing print head. The head counter should be reset each time the print head is replaced.
<div style="border: 1px solid black; padding: 5px; width: fit-content;">                     DISPENSE COUNTER XX.XM                 </div>	Is an informational screen that provides the dispense cycles of media since dispenser installation or use.
<div style="border: 1px solid black; padding: 5px; width: fit-content;">                     CUT COUNTER X                 </div>	Is an informational screen that provides the cut cycles of media since cutter installation or use.
<div style="border: 1px solid black; padding: 5px; width: fit-content;">                     LIFE COUNTER XX.XM                 </div>	Is an informational screen that provides the printed the length of media since printer setup.

COUNTERS MODE (TABLE 4-7)	
MENU	DESCRIPTION
<div style="border: 1px solid black; padding: 5px; width: fit-content;">                     HEAD COUNTER CLEAR                      YES      NO                 </div>	Allows the determination of whether or not to reset the print head counter to zero.
<div style="border: 1px solid black; padding: 5px; width: fit-content;">                     DSP COUNTER CLEAR                      YES      NO                 </div>	Allows the determination of whether or not to reset the dispenser counter to zero.
<div style="border: 1px solid black; padding: 5px; width: fit-content;">                     CUT COUNTER CLEAR                      YES      NO                 </div>	Allows the determination of whether or not to reset the cutter counter to zero.

TEST PRINT MODE (TABLE 4-8)	
MENU	DESCRIPTION
<div style="border: 1px solid black; padding: 5px; width: fit-content;">                     TEST PRINT MODE                      CONFIGURATION                      BARCODE                      HEADCHECK                      MEMORY                      FACTORY                 </div>	Is the initial screen of the Test Print Mode. <ul style="list-style-type: none"> <li>• <b>CONFIGURATION:</b> The printer's configuration settings.</li> <li>• <b>BARCODE:</b> The printer's installed barcodes.</li> <li>• <b>HEAD CHECK:</b> A pattern to check print head elements.</li> <li>• <b>FONT:</b> The contents of the installed fonts.</li> <li>• <b>FACTORY:</b> A factory test label will be printed.</li> </ul>
<div style="border: 1px solid black; padding: 5px; width: fit-content;">                     TEST PRINT SIZE                      XXCM                 </div>	This menu screen only appears if CONFIGURATION, BARCODE, or HEAD CHECK was chosen in the previous menu. The increments of measure is 1cm.
<div style="border: 1px solid black; padding: 5px; width: fit-content;">                     PRINT SIZE                      SMALL    LARGE                 </div>	For factory test prints, this screen appears instead of the previous screen for setting print size. Large (10cm) and small (4cm) are the only two options.
<div style="border: 1px solid black; padding: 5px; width: fit-content;">                     PRESS FEED KEY                      TO STOP PRINTING                 </div>	Is a directional screen prompting action on how to terminate print activity. Press FEED to stop printing and press again to resume printing.

BOOT DOWNLOAD MODE (TABLE 4-9)	
MENU	DESCRIPTION
<div style="border: 1px solid black; padding: 5px; width: fit-content;">                     BOOT DOWNLOADER                      PRESS FEED KEY                 </div>	Is the first menu screen of the Boot Download Mode and provides a prompt to proceed. Pressing the FEED key will place the printer in a condition waiting for the data to be received.

BOOT DOWNLOAD MODE (TABLE 4-9)	
MENU	DESCRIPTION
<div style="border: 1px solid black; padding: 5px; width: fit-content;">                     DOWNLOAD SELECT INTERFACE CARD                 </div>	Select the INTERFACE option for a standard download.
<div style="border: 1px solid black; padding: 5px; width: fit-content;">                     PROGRAM DOWNLOAD READY                 </div>	Is an informational screen only and confirms that the printer is ready to receive the data.
<div style="border: 1px solid black; padding: 5px; width: fit-content;">                     PROGRAM DOWNLOAD START &gt;&gt;&gt; END                 </div>	Provides download status that the data is being received and its progression.
<div style="border: 1px solid black; padding: 5px; width: fit-content;">                     DOWNLOAD COMPLETE PRESS FEED KEY                 </div>	This menu screen appears when all of the data has been received and the process is complete. Also prompts the operator on how to proceed.

FLASH DOWNLOAD MODE (TABLE 4-10)	
MENU	DESCRIPTION
<div style="border: 1px solid black; padding: 5px; width: fit-content;">                     FLASH DOWNLOAD READY                 </div>	Is an informational screen only and confirms that the printer is ready to receive the data.
<div style="border: 1px solid black; padding: 5px; width: fit-content;">                     PROGRAM DOWNLOAD START &gt;&gt;&gt; END                 </div>	Provides download status that the data is being received and its progression.
<div style="border: 1px solid black; padding: 5px; width: fit-content;">                     DOWNLOAD COMPLETE PRESS FEED KEY                 </div>	This menu screen appears when all of the data has been received and the process is complete. Also prompts the operator on how to proceed.

DEFAULT SETTING MODE (TABLE 4-11)	
MENU	DESCRIPTION
<div style="border: 1px solid black; padding: 5px; width: fit-content;">                     DEFAULT SETTING YES NO                 </div>	<p>Is the first menu screen of the printer's Default Setting Mode. The Default Setting Mode allows the printer to be reset to the programmed condition as received from the factory.</p> <p>The selection of YES confirms the operator wants to proceed and the selection of NO allows for exit without default reset. If YES is selected, resetting will immediately begin.</p> <p>Reboot the printer to return to normal operation.</p>
<div style="border: 1px solid black; padding: 5px; width: fit-content;">                     DEFAULT SETTING COMPLETED                 </div>	Is an informational screen only indicating that reset activity is complete.

HEX DUMP MODE (TABLE 4-12)	
MENU	DESCRIPTION
<div style="border: 1px solid black; padding: 5px; width: fit-content;">                     ONLINE                      QTY: XXXXXX                 </div>	Displays to indicate the printer is online and waiting to print HEX interpretation of data received by the print buffer.

MAINTENANCE MODE (TABLE 4-13)	
MENU	DESCRIPTION
<div style="border: 1px solid black; padding: 5px; width: fit-content;">                     MAINTENANCE MODE                      DIPSW2-4 ON-&gt;OFF                 </div>	Is the first menu screen of the Maintenance Mode and provides a prompt on the action required to proceed to the Factory Mode.
<div style="border: 1px solid black; padding: 5px; width: fit-content;">                     FACTORY MODE                 </div>	<p>The Factory Mode is divided into two sub-menus: the All Clear Mode and the individual Counter Clear.</p> <p>The All Clear Mode permits the operator to entirely clear all of the printer's internal counters or to clear its EEPROM of all data.</p> <p>Counter Clear permits the operator to select individual counters to be reset to zero.</p>
<div style="border: 1px solid black; padding: 5px; width: fit-content;">                     ALL CLEAR MODE                 </div>	<p>Is a transitional, informational menu screen to inform of the coming menu functions. Pressing LINE, retreats one menu screen to allow the operator to change direction within the menu.</p> <p>Pressing FEED advances onward to allow the operator to entirely clear either the printer's internal counters and/or, its EEPROM data.</p>
<div style="border: 1px solid black; padding: 5px; width: fit-content;">                     ALL CLEAR                      COUNTER EEPROM                 </div>	<p>Allows the selection of the direction to proceed within the menu tree. Selecting COUNTER will advance to menu screens that will allow the printer's internal counters to be reset to zero.</p> <p>Selecting EEPROM will advance to menu screens that will allow the printer's EEPROM to be emptied of data.</p>
<div style="border: 1px solid black; padding: 5px; width: fit-content;">                     COUNTER ALLCLEAR                      YES NO                 </div>	Allows the selection of whether to clear all of the printer's internal counters or not. Select YES to clear and NO to not clear.
<div style="border: 1px solid black; padding: 5px; width: fit-content;">                     EEPROM ALLCLEAR                      YES NO                 </div>	Allows the selection of whether to clear all of the printer's EEPROM or not. Select YES to clear and NO to not clear.
<div style="border: 1px solid black; padding: 5px; width: fit-content;">                     COUNTER ALLCLEAR                      COMPLETED                 </div>	Is an informational screen only. Momentarily displays when the printer's internal counters are reset to zero and then automatically returns to the ALL CLEAR MODE screen.
<div style="border: 1px solid black; padding: 5px; width: fit-content;">                     EEPROM ALLCLEAR                      COMPLETED                 </div>	Is an informational screen only. Momentarily displays when the printer's EEPROM has been emptied of data and then automatically returns to the ALL CLEAR MODE screen.

MAINTENANCE MODE (TABLE 4-13)	
MENU	DESCRIPTION
<div style="border: 1px solid black; padding: 5px; background-color: #e6f2e6;">                     COUNTER CLEAR                      NONE                      ALL                      HEAD                 </div>	<p>This screen allows the selection of which of the printer's internal counters are to be cleared or not at all. Following the process, factory test printing is performed.</p>
<div style="border: 1px solid black; padding: 5px; background-color: #e6f2e6;">                     PRINT SIZE                      SMALL    LARGE                 </div>	<p>Allows the selection of large (10cm) or small (4cm) font print size for the printing of a factory test page. These are the only two options.</p>
<div style="border: 1px solid black; padding: 5px; background-color: #e6f2e6;">                     TEST PRINT                      PRESS FEED KEY                 </div>	<p>Pressing FEED will initialize continuous test printing. Pressing FEED again will suspend printing.</p>

# 5

## **TROUBLESHOOTING**

- **Error Signal Troubleshooting**
- **Troubleshooting Table**
- **Interface Troubleshooting**
- **Test Print Modes**



## ERROR SIGNAL TROUBLESHOOTING

ERROR DISPLAYS			
ERROR	LED	LCD DISPLAY	DESCRIPTION
<b>01 Machine</b>	Red	MACHINE ERROR	<ol style="list-style-type: none"> <li>1. Ensure all wiring harnesses are properly connected.</li> <li>2. Replace main circuit board.</li> </ol>
<b>02 Flash ROM</b>	Red	EEPROM ERROR	<ol style="list-style-type: none"> <li>1. Ensure correct communication protocols.</li> <li>2. Check cables, cycle printer power and resend.</li> <li>3. Replace board.</li> </ol>
<b>03 Parity</b>	Red	PARITY ERROR	<ol style="list-style-type: none"> <li>1. Ensure correct communication parameters.</li> <li>2. Check cables, cycle printer and resend.</li> <li>3. Replace board.</li> </ol>
<b>04 Overrun</b>	Red	OVERRUN ERROR	<ol style="list-style-type: none"> <li>1. Check and correct communication cables and settings.</li> </ol>
<b>05 Framing</b>	Red	FRAMING ERROR	<ol style="list-style-type: none"> <li>1. Ensure host system and interface settings match.</li> <li>2. Check and correct communication cables. (null modem serial cable required)</li> </ol>
<b>06 Buffer Overflow</b>	Red	BUFFER OVER	<ol style="list-style-type: none"> <li>1. Size of received data exceeds size of receiving buffer.</li> <li>2. Establish the correct communication protocol.</li> </ol>
<b>07 Head Open</b>	Red	HEAD OPEN	<ol style="list-style-type: none"> <li>1. Properly latch the print head.</li> <li>2. Replace the head-open switch.</li> </ol>
<b>08 Paper End</b>	Red	PAPER END	<ol style="list-style-type: none"> <li>1. Ensure media is properly loaded.</li> <li>2. Clean sensor transmit/receive surfaces.</li> <li>3. Ensure correct sensor configuration.</li> </ol>
<b>09 Ribbon End</b>	Red	RIBBON END	<ol style="list-style-type: none"> <li>1. Ensure ribbon stock is properly loaded.</li> <li>2. Ensure ribbon has not been damaged.</li> <li>3. Ensure proper printer configuration.</li> </ol>
<b>10 Sensor Error</b>	Red	SENSOR ERROR	<ol style="list-style-type: none"> <li>1. Ensure media is properly loaded.</li> <li>2. Clean sensor transmit/receive surfaces.</li> <li>3. Ensure correct sensor configuration.</li> </ol>
<b>11 Head Related</b>	Red	HEAD ERROR	<ol style="list-style-type: none"> <li>1. Clean the print head's contact surface.</li> <li>2. Replace the print head.</li> </ol>
<b>12 Memory Reading</b>	Red	DOWNLOAD ERROR XXXXXXXXX ERROR	<ol style="list-style-type: none"> <li>1. Delete unnecessary data to free up memory space.</li> <li>2. Ensure the data communication settings are correct.</li> </ol>
<b>13 Interface</b>	Red	DOWNLOAD ERROR I/F NOT SUPPORTED	<ol style="list-style-type: none"> <li>1. Data sequence number doesn't match previous data.</li> <li>2. Check send data and communications setting.</li> </ol>
<b>14 Download Data</b>	Red	DOWNLOAD ERROR DATA ERROR	<ol style="list-style-type: none"> <li>1. Confirm settings are correct.</li> <li>2. Retry command.</li> </ol>
<b>15 Download Write</b>	Red	DOWNLOAD ERROR WRITE ERROR	<ol style="list-style-type: none"> <li>1. Confirm settings are correct.</li> <li>2. Retry command.</li> </ol>
<b>16 Head Mis-Match</b>	Red	HEAD MISMATCH	<ol style="list-style-type: none"> <li>1. Ensure print head is properly connected.</li> <li>2. Ensure the print head type and printer configuration.</li> </ol>

# TROUBLESHOOTING TABLE

<b>TROUBLESHOOTING TABLE</b>	
<b>IMAGE VOIDS</b>	
Dirty print head.	Clean print head.
Damaged print head.	Replace print head.
Damaged electronics.	Replace circuit board.
Damaged or worn roller.	Replace rollers.
Poor label quality.	Use higher quality media.
Ribbon stock and media are mismatched.	Consult with media supplier.
<b>RIBBON WRINKLING</b>	
Poor head alignment.	Adjust head balance and alignment.
Excessive temperature setting	Adjust temperature.
Poor ribbon tension.	Adjust tension as required.
Worn roller.	Replace as necessary.
Foreign material on print head and/or rollers.	Clean as required.
Foreign material on labels.	Use higher quality media.
Damaged print head.	Replace print head as required.
<b>LIGHT PRINT IMAGES</b>	
Low print head energy/darkness.	Adjust darkness level.
Low print head pressure.	Adjust head pressure and/or balance.
Foreign material on print head.	Clean print head and rollers.
Improper head alignment.	Align print head as required.
Excessive print speed.	Reduce print speed setting.
<b>UNEVEN PRINT DARKNESS</b>	
Unbalanced print head.	Adjust head balance.
Worn rollers.	Replace rollers as required.
Dirty print head.	Clean print head.
<b>MEANDERING MEDIA</b>	
Incorrectly loaded media.	Ensure correct loading.
Improperly adjusted media guides.	Adjust as required.
Unbalanced print head.	Adjust as required.
Worn rollers.	Replace as required.
<b>NO LABEL MOVEMENT</b>	
Loose or broken timing belt.	Replace or adjust as required.
Incorrect label sensor selected.	Check printer configuration for proper sensor selection.
No voltage output.	Replace fuse. Test power supply and replace as required.
Drive motor not operating.	Ensure wiring harness connection. Replace as necessary.
<b>LCD FIELD ILLUMINATED BUT WITHOUT WORDS OR NO DISPLAY AT ALL</b>	
Power supply issues.	Ensure cable properly connected. Check/replace power supply.
Incorrectly positioned display potentiometer.	Adjust as required.

<b>NO PRINTED IMAGE</b>	
Print head is disconnected.	Ensure print head wiring harness is connected on each end.
No voltage output.	Replace fuse. Test power supply and replace as required.
Defective print head.	Replace print head and reset counter.
Damaged electronics.	Replace circuit board.
Interface problems.	Troubleshoot interface - refer to the next chapter.
Data input error.	Ensure correct data stream.
<b>PRINTER CREATES A BLANK LABEL.</b>	
Data input error.	Ensure correct data stream.
Incorrect label sensor selection.	Ensure correct printer configuration.
Disconnected print head.	Power off the printer and ensure a proper connection.
Defective print head.	Replace print head as required.
Defective main circuit board.	Replace main board as required.
<b>INCORRECT LABEL POSITIONING.</b>	
Incorrect label sensor selection.	Ensure correct printer configuration.
Improper sensor adjustment.	Adjust sensor sensitivity as required.
Data input error.	Ensure correct data stream.
Incorrect offset settings.	Adjust settings as required.
Incorrect applicator setup.	Refer to applicator documentation or contact manufacturer.
<b>SMEARED PRINT IMAGES</b>	
Poor media quality.	Use higher quality media.
Foreign material on print head and platen roller.	Clean print head and rollers.
Foreign material on labels.	Use higher quality media.
Excessive print head energy.	Adjust darkness setting.
Excessive print speed.	Adjust print speed as required.

## INTERFACE TROUBLESHOOTING

This chapter provides a checklist for the various interface types. Locate the checklist relative to the interface used and perform each of the troubleshooting tasks until the problem has been isolated.

<b>PARALLEL INTERFACE</b>	
<b>CHK</b>	<b>TROUBLESHOOTING STEP</b>
	Ensure the interface module is correctly installed. Run self-test to verify.
	Ensure the printer cable is connected to the appropriate LPT port on the host computer. If using a Windows printer driver, ensure the correct port is selected.
	Ensure a IEEE1284 printer cable is being used.
	Ensure the host's peripheral settings are set to ECP for faster throughput. Refer to the computer manufacturer's documentation for details.
	Ensure the printer is receiving information from the computer using the Receive Buffer Hex Dump mode. Refer to that procedure within this manual for instructions. The command stream should be continuous and possess 0Dhex and/or 0Ahex (carriage return and line feed) characters throughout. However, there should not be either located between the start (<ESC>A and the stop (<ESC>Z) commands.
	Replace the interface board with another to isolate the problem.
	Replace the interface board permanently if determined to be the problem.

<b>RS232 SERIAL INTERFACE</b>	
<b>CHK</b>	<b>TROUBLESHOOTING STEP</b>
	Ensure the correct interface module is correctly installed. Run self-test to verify.
	Ensure the serial cable (Null Modem) meets specifications and is correctly connected at each end.
	Ensure the serial cable is not defective.
	Ensure the communication parameters for the baud rate, parity, data bits and stop bits are consistent with those being sent from the host computer.
	Ensure the printer is receiving information from the computer using the Receive Buffer Hex Dump mode. Refer to that procedure within this manual for instructions. The command stream should be continuous and possess 0Dhex and/or 0Ahex (carriage return and line feed) characters throughout. However, there should not be either located between the start (<ESC>A and the stop (<ESC>Z) commands.
	Replace the interface board with another to isolate the problem.
	Replace the interface board permanently if determined to be the problem.

<b>UNIVERSAL SERIAL BUS (USB) INTERFACE</b>	
If nothing prints during a test print, verify the device drivers have been successively installed by performing the following:	
<b>CHK</b>	<b>TROUBLESHOOTING STEP</b>
	Click on Start, Settings, and then Control Panel.
	Click on System within the new window.
	Click on the Device Manager tab.
	Ensure that the View Device By Type is checked.
	Scroll to SATO-USB Device and ensure that errors do not exist. Reinstall as required.
	Reboot the PC and the printer.
	Contact Microsoft technical support for further assistance as required.

<b>LAN ETHERNET INTERFACE</b>	
<b>CHK</b>	<b>TROUBLESHOOTING STEP</b>
	Ensure the interface has been correctly configured. Wait two minutes and run self-test to verify. If a test label does not print, there may be a hardware problem.
	Ensure the cable and its ports are not defective.
	Ensure that a faulty print server or other protocol related scenarios are not creating a queue setup issue. Systematically perform checks and tests to isolate the cause.
	If using TCP/IP, ensure a valid IP address is specified and that all parameters are correct (subnet mask, gateway, etc.). Attempt to PING the IP address assigned to the network interface.
	If using a repeater or hub, ensure the SQE is turned off. Also ensure the repeater port is not defective by trying the print server on another port.
	Install the IPX/SPX protocol on a workstation to determine if the network device can be discovered via the MAC address. If able, configure the appropriate protocols and retest connectivity.
	Use a crossover cable to isolate the printer from the network by connecting from the interface and workstation. Verify that the parameters match on each. Test connectivity.

<b>802.11G WIRELESS INTERFACE</b>	
<b>CHK</b>	<b>TROUBLESHOOTING STEP</b>
	Ensure the antenna is properly and completely installed.
	Ensure the interface is properly seated in the printer.
	Ensure the green connection lights on the back of the interface board are illuminated.
	If not obtaining an IP address, check the SSID or encryption and ensure those were properly entered.
	To determine the IP address obtained through the DHCP wireless device, power off the printer, place switch 3 in the upward position on the wireless card and reinsert it into the printer, and power the printer on. Wait approximately 30 seconds for a print out of configurations.

<b>CENTRONICS INTERFACE</b>	
<b>CHK</b>	<b>TROUBLESHOOTING STEP</b>
	Ensure the interface module is correctly installed. Run self-test to verify.
	Ensure the printer cable is connected to the appropriate LPT port on the host computer. If using a Windows printer driver, ensure the correct port is selected.
	Ensure the host's peripheral settings are set for Centronics output for faster throughput. Refer to the computer manufacturer's documentation for details.
	Ensure the printer is receiving information from the computer using the Receive Buffer Hex Dump mode. Refer to that procedure within this manual for instructions. The command stream should be continuous and possess 0Dhex and/or 0Ahex (carriage return and line feed) characters throughout. However, there should not be either located between the start (<ESC>A and the stop (<ESC>Z) commands.
	Replace the interface board with another to isolate the problem - permanently replace if defective.

## TEST PRINT TROUBLESHOOTING

---

Chapter provides instruction on special printing to identify and resolve specific print problems.

<b>HEX DUMP</b>	Allows the operator to determine if there were problems in the downloading of data.
<b>TEST LABEL</b>	Allows the operator to identify specific problems regarding mechanical performance and setup.

### HEX DUMP MODE

The contents of the print buffer can be examined using the Hex Dump Mode. In the left column, each line of data received is numbered. The center column provides the data in hexadecimal format. And in the right column, same data is provided in the ASC II format. Follow the flow chart provided below to perform this activity.

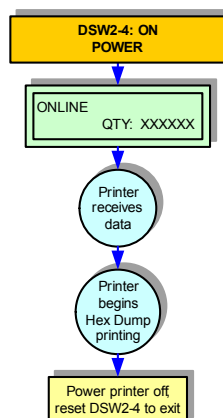

Figure 5-1, Hex Dump Mode

## TEST LABEL PRINTING

The test label is designed to assist in the identification of print problems. Follow the flow chart provided below to perform this activity.

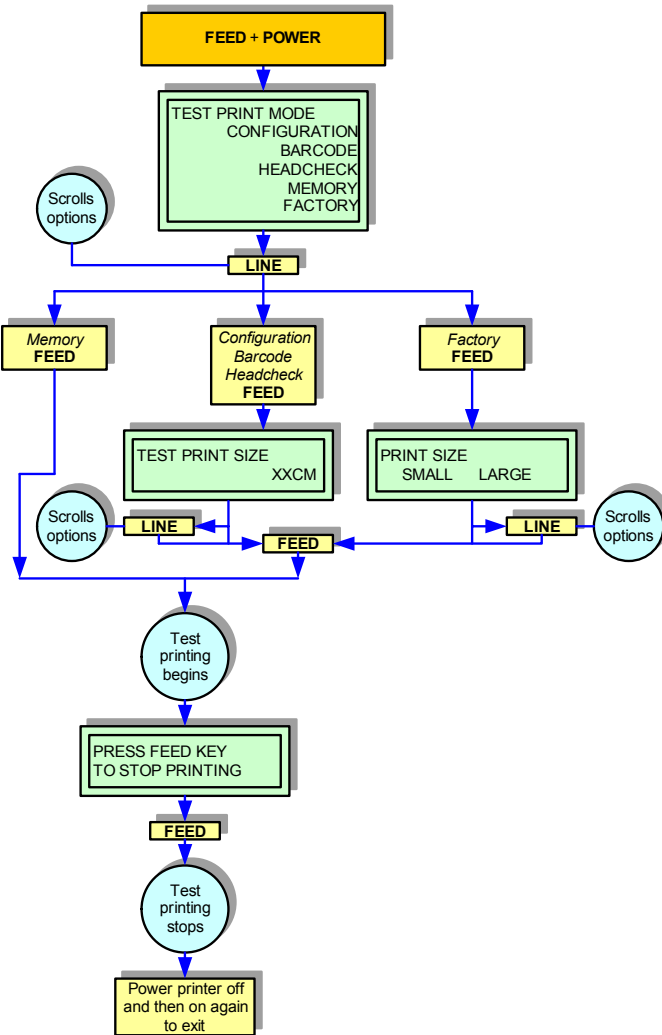

Figure 5-2, Test Print Mode

NOTE: The only print problem that the following sample test label does not display is fading of print image from one side of the label to the other. This is the result of improper print head balance.

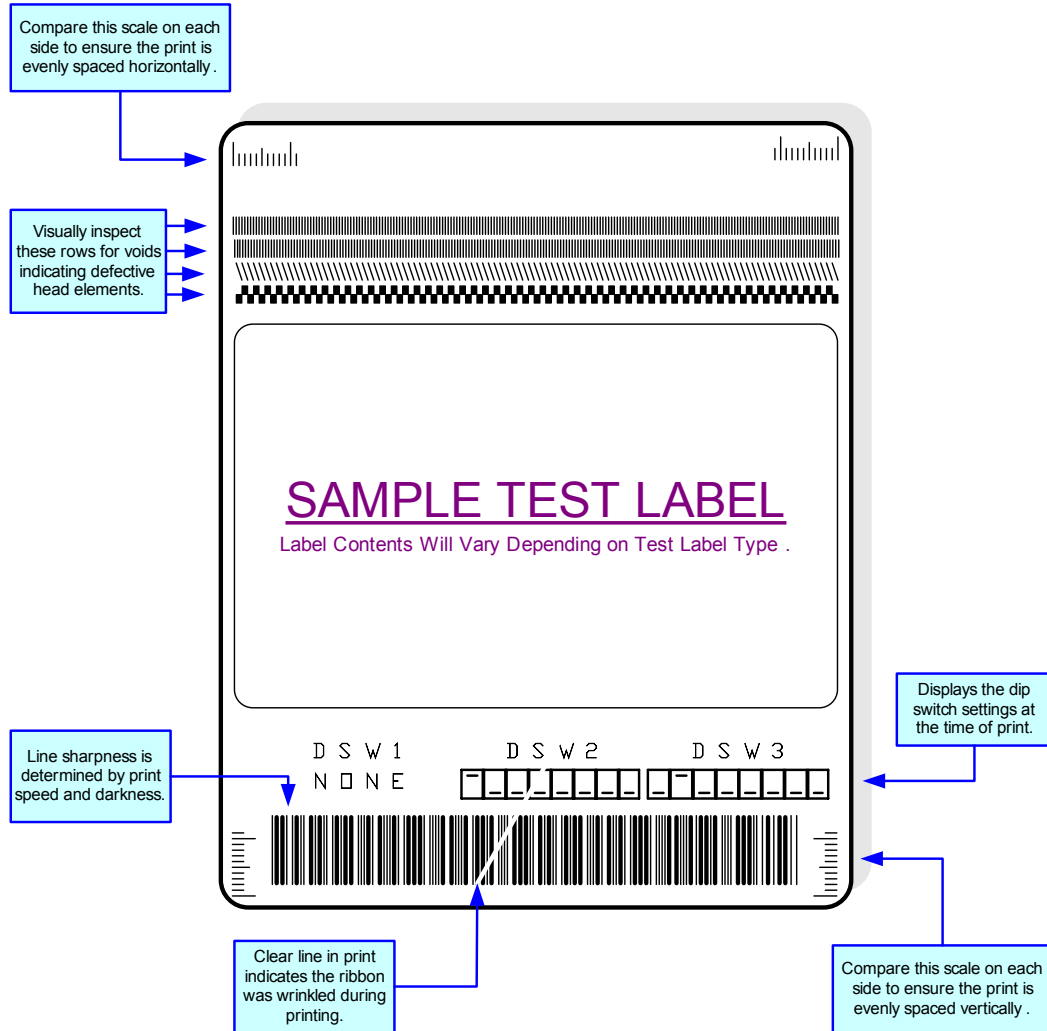

Figure 5-3, Sample Test Label



# 6

## **MAINTENANCE**

- **Cleaning Procedures**
- **Replacement Procedures**
- **Adjustment Procedures**

## CLEANING PROCEDURES

---

Cleaning of the printer is a necessary maintenance activity to ensure print quality and longer printer life. There are two basic types of cleaning involved; the removal of loose debris and the removal of residue.

Use a soft cloth and/or a pneumatic blower to remove debris from the printer. This process should be performed prior to the removal of residue. To remove residue, apply SATO Solvent or isopropyl alcohol to a clean cotton swab and gently wipe the entire surface of the print head and platen roller clean.

**WARNING: DISCONNECT POWER SUPPLY TO THE PRINTER AND ALLOW TO COOL TO ROOM TEMPERATURE PRIOR TO CLEANING. EXERCISE CARE WHEN CLEANING TO PREVENT PERSONAL INJURY.**

**CAUTION: IF USING A PNEUMATIC BLOWER TO REMOVE DEBRIS FROM THE PRINTER, EXERCISE CARE TO PREVENT PRINT HEAD DAMAGE.**

## REPLACEMENT PROCEDURES

This chapter provides in-depth instruction on all primary component and assembly replacement, in addition to most secondary components. Use the text in conjunction with their accompanied graphics to ensure complete comprehension throughout the process. Especially observe all cautionary or warning notations.

### PRINT HEAD REPLACEMENT

If the print head becomes damaged or worn, it can be easily removed and replaced without having to make critical adjustments. Before replacing the print head, check the head counter values by printing a test pattern. Instructions relating to the Head Counter may be found in the Configuration unit of this manual.

1. Switch off the printer and disconnect power supply cord.
2. Open the right housing cover and latch print head release lever (1, Figure 6-1a) as necessary.
3. Remove screw (2) from upper print assembly (3) securing defective print head (4, Figure 6-1b).
4. Unlatch print head release lever (1) and withdraw defective print head (4) from within print assembly (3).
5. Disconnect the two wiring harnesses (not shown) from defective print head (4).
6. Reconnect two wiring harnesses (not shown) to replacement print head (4).

**NOTE:** Each of the printer's wiring harness connectors are different from all others to ensure proper mating. Mate each matching half for reconnection.

7. Insert replacement print head (4) into print assembly (3) and latch lever (1, Figure 6-1a).

**NOTE:** Apply the print to the upper surface of the print assembly's print bracket and ensure the alignment pins insert into their respective slots.

8. Secure replacement print head (4) to print assembly (3) and secure using screw (2).
9. Restore power, reset the head counter, and test print.

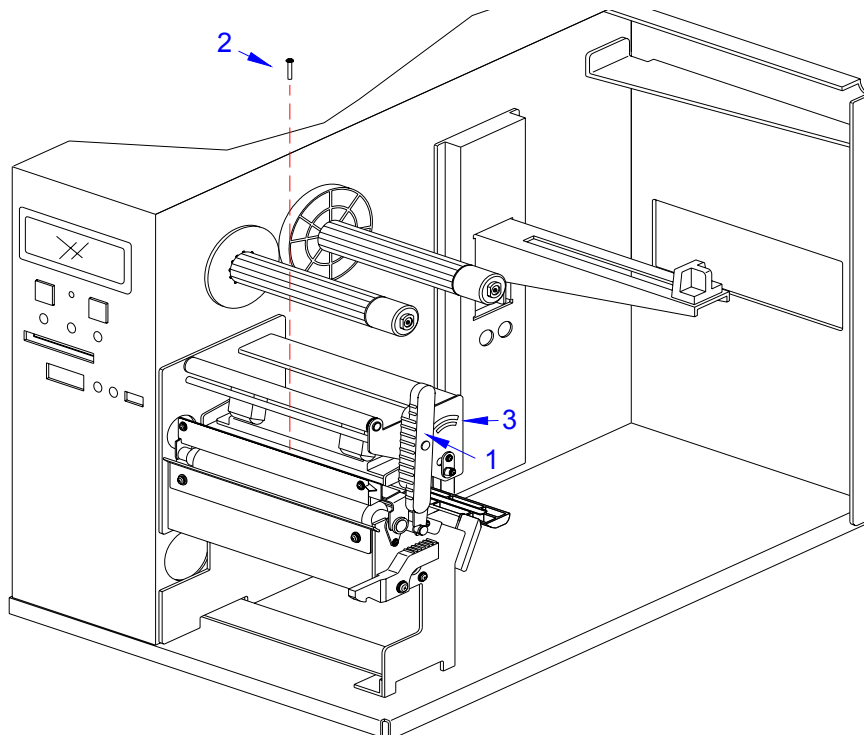

**Figure 6-1a, Print Head Replacement**

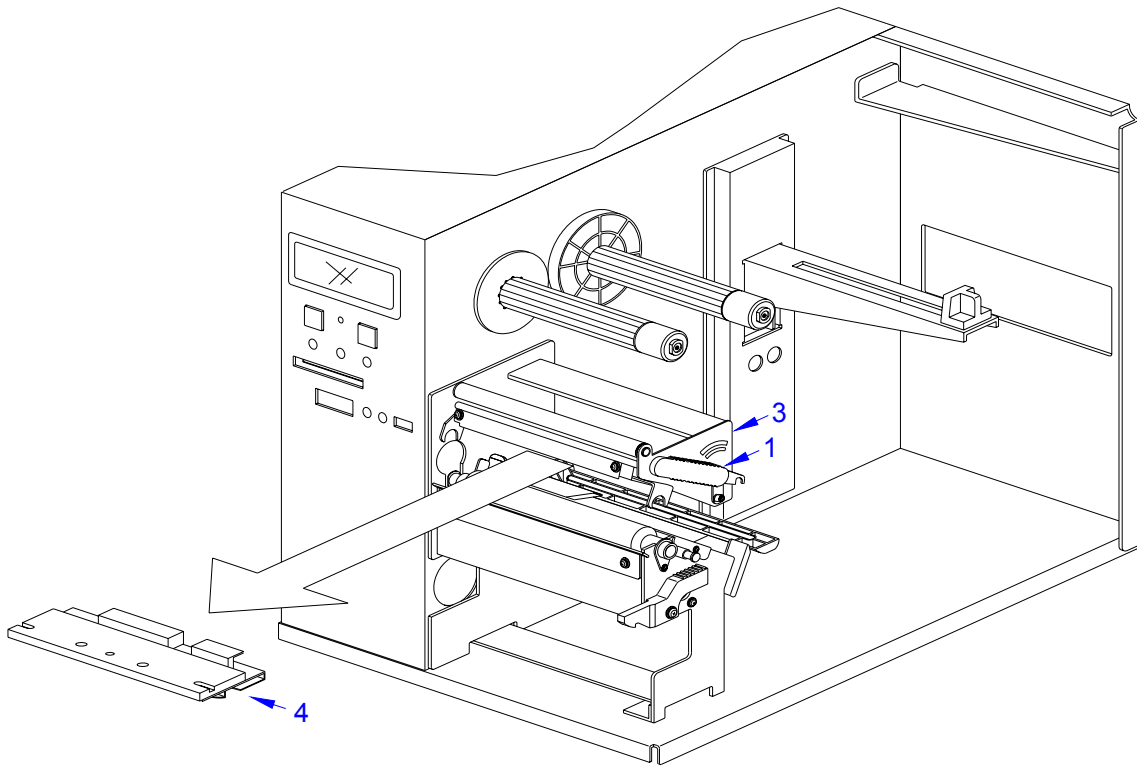

Figure 6-1b, Print Head Replacement

## INTERFACE BOARD REPLACEMENT

Circuit boards generally have long lives due to the lack of moving parts. Generally, if a circuit board becomes defective, it is contributable to a negative external condition.

If it is determined that the circuit board has become defective, search the printer over for possible visual factors that may have led to the damage.

1. Switch off the printer and disconnect power supply cord.
2. Disconnect interface cable (1, Figure 6-2) from defective interface board (2).
3. Remove two screws (3) securing defective interface board (2) to printer (4).
4. Insert replacement interface board (2) into printer (4) and secure using two screws (3).
5. Connect interface cable (1).

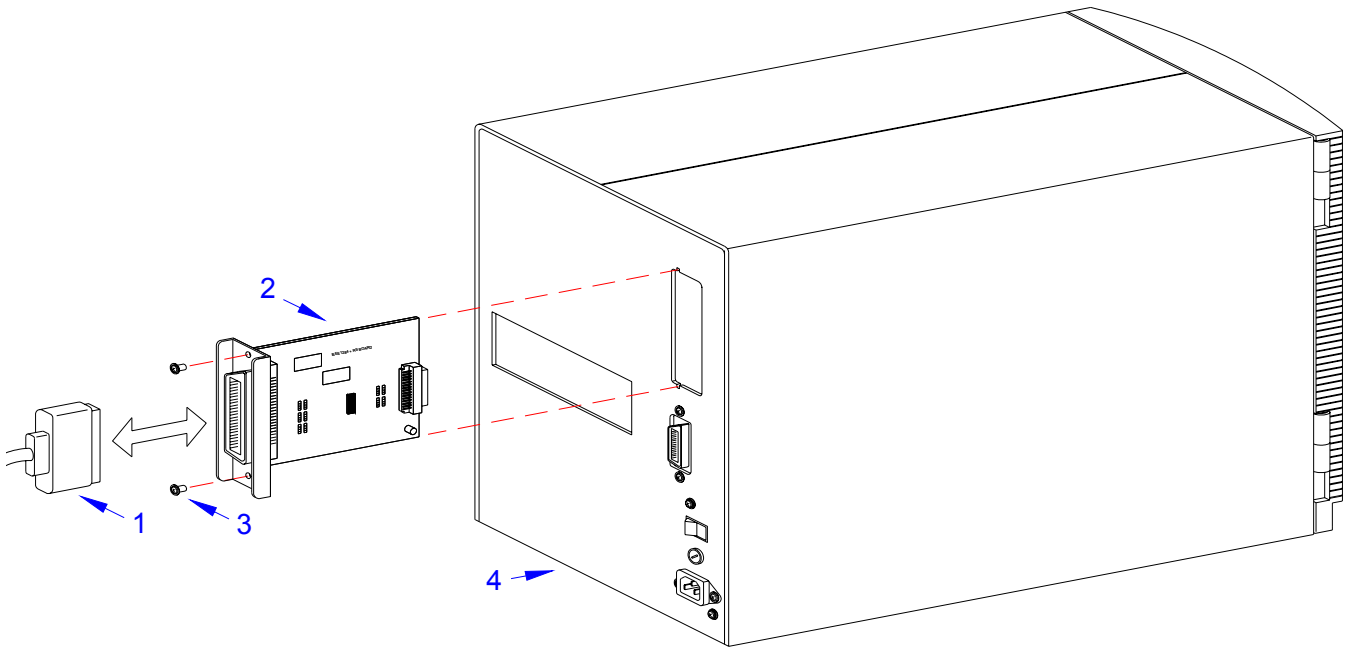

Figure 6-2, Interface Board Replacement

## FUSE REPLACEMENT

The fuse is wired to the power receptacle and protects the printer from power surges from the electrical source. If a surge of electricity reaches the fuse, its filament will melt creating a disruption of the flow. In order to bridge the gap so the printer may again be functional, the damaged fuse must be replaced.

1. Switch off the printer and disconnect power supply cord.
2. Unscrew fuse cap (1, Figure 6-3) from fuse cylinder (2) located on rear housing cover (3).
3. Withdraw damaged fuse (4) from fuse cap (1) and insert replacement fuse (4) in its place.
4. Insert replacement fuse (4) into fuse cylinder (2) and screw on cap (1).

**NOTE:** The fuses may be inspected by looking for a void in its filament or by using a multimeter to check for circuit continuity.

**NOTE:** Fuse amperage and voltage rating may be found stamped into the fuse's metal contacts or labeled on the printer's rear.

**NOTE:** The orientation of the fuse does not matter. It only has to be installed into its respective cylinder and be able to make contact on each end to function.

**CAUTION:** IMPROPER FUSE USAGE MAY RESULT IN DESTROYED ELECTRICAL COMPONENTS AND/OR FIRE. ENSURE THE DAMAGED FUSE IS REPLACED WITH ONE OF IDENTICAL PHYSICAL DIMENSIONS AND AMPERAGE. TO DO THIS, DUPLICATE THE INFORMATION STAMPED ON THE FUSE'S METAL CASING.

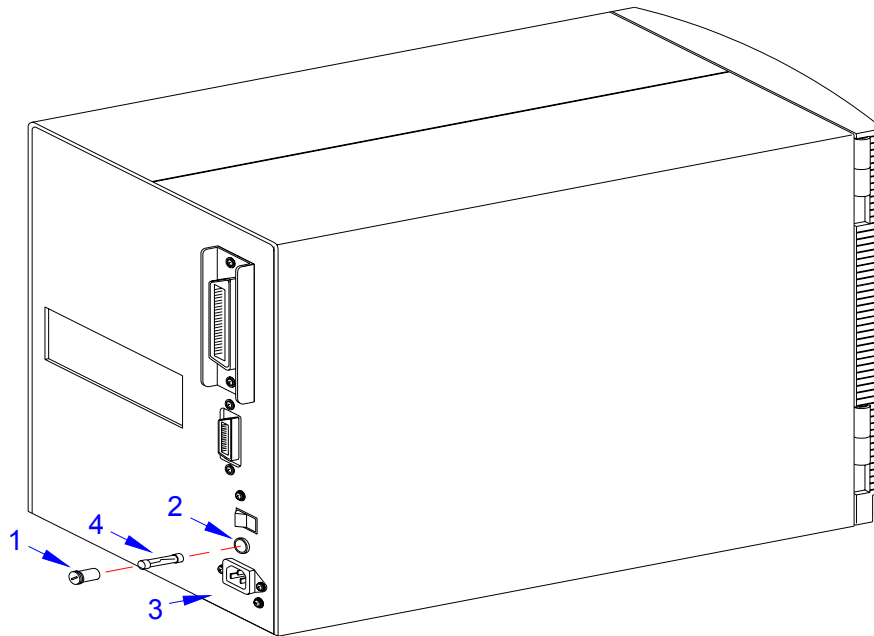

**Figure 6-3, Fuse Replacement**

## ADJUSTMENT PROCEDURES

This chapter covers all of the printer and printer accessory adjustments. These adjustments include mechanical adjustments required following the replacement of components and assemblies, in addition to, the operational adjustments required following a job change.

### PRINT HEAD BALANCE ADJUSTMENT

Print head balance is the equalization of pressure against the platen roller from one end to the opposite. If the print head balance is out of adjustment, the printed image will be darker on one side of the label than the other and the media will be prone to travel in the direction of least resistance.

The adjustment of print head balance on the label can be subjective. One will know when balance is achieved by the disappearance of prevailing negative print characteristics.

To adjust the balance, begin test printing, slightly loosen set screw (1, Figure 6-4), and slightly move adjustment plate (2) to the right or left as necessary. Retighten set screw (1) while holding adjustment plate (2) when proper printing is achieved.

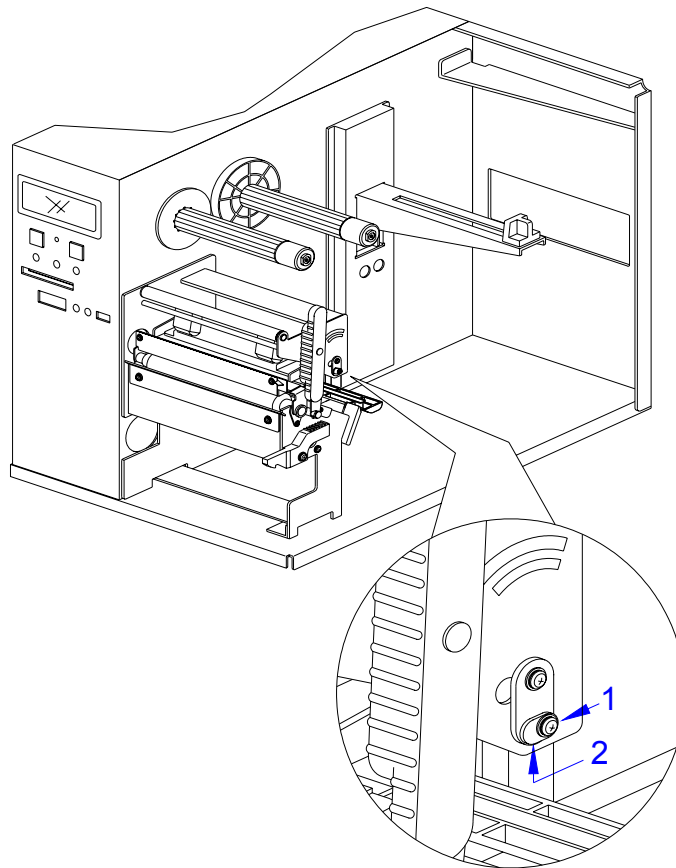

Figure 6-4, Print Head Balance Adjustment

## PRINT HEAD ALIGNMENT

Print head position has a direct impact on print quality. The print head must be parallel with the platen roller for the printed image to be consistent across the label.

- 1 Open the right housing cover to access print assembly (1, Figure 6-5a).
- 2 Ensure print head (2) is latched (3).
- 3 Look downward to print head (2) to locate head alignment plate (4, Figure 6-5b).
- 4 Ensure the values of alignment scales (A) and (B) are the same.

NOTE: If the scale values are not the same, this may be the cause of print quality issues. However, matching scale values does not ensure proper alignment. If the scales do not match, for this procedure to align the scales, reprint, and then readjust as deemed necessary.

- 5 Determine which end of alignment plate (4) should be adjusted and loosen its relative set screw (5) or (6).
- 6 Adjust alignment plate (4) then retighten relative set screw (5, 6) while maintaining plate position.

NOTE: There is a slot at each adjustment scale (A, B) in alignment plate (4) where an object may be inserted to assist in adjustment. An appropriately sized Standard screwdriver works best.

- 7 Test print a label to determine if print head (2, Figure 6-5a) is properly aligned.
- 8 Repeat this procedure until proper alignment is achieved.

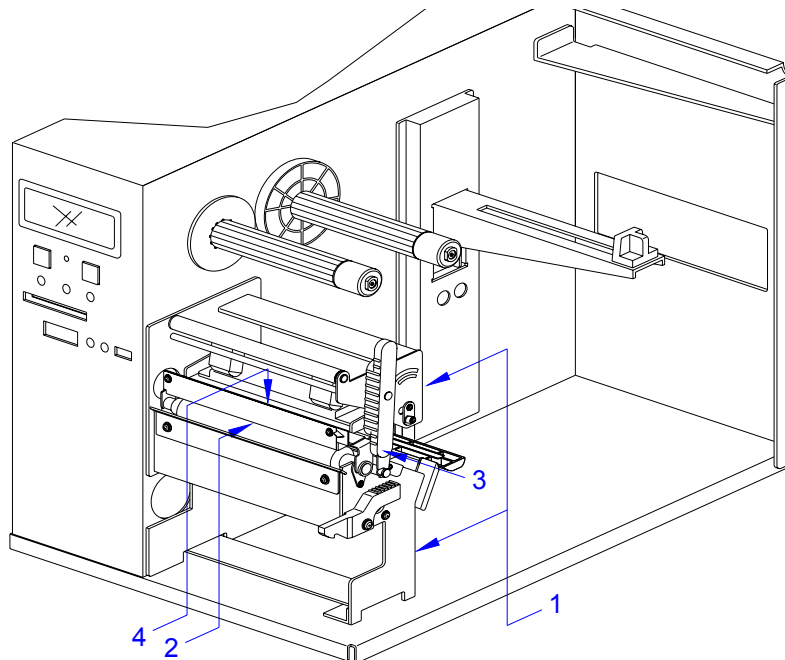

Figure 6-5a, Print Head Alignment

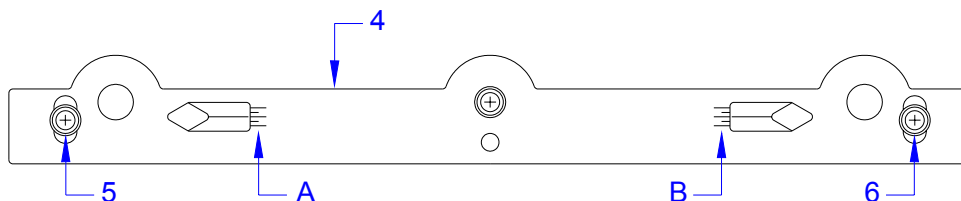

Figure 6-5b, Print Head Alignment



## RIBBON GUIDE ALIGNMENT

If the print ribbon is not spread smoothly over the print head when it makes contact with the media, print voids will occur at the point of the ribbon fold. Typically, this is the result of the axis of one of the following not being perfectly parallel with the platen roller: ribbon spindle, print head, or ribbon guide.

The purpose of the adjustable ribbon guide is to compensate for the axis deviations of the other two. By adjusting the ribbon guide proportionally to the degree of deviation, the ribbon spreads smoothly as it travels from the ribbon supply spindle, to the guide, and beyond.

Ribbon guide adjustment is a trial and error activity that requires the pause of printing, unlatching of the print head, adjusting the guide, relatching the print head, and printing once again. Several labels must be printed following each adjustment to determine if the adjustment was effective.

The ribbon guide is secured to the face of the print assembly by a screw on each end. Before adjusting the guide, visually inspect that its axis is parallel with that of the print assembly. If not, adjust accordingly, ensure the set screws are secure, and once again commence printing. By starting in a neutral position, either end may be adjusted vertically as necessary to remedy the wrinkling problem.

**NOTE:** To facilitate viewing of pertinent components, Figure 6-6 does not show ribbon and media loaded. When performing this adjustment activity, both must be loaded.

- 1 Test print a label to ensure the print head is properly balanced and aligned.

**NOTE:** Refer to their relative procedures within this manual for guidance on Print Head Balance and Print Head Alignment.

- 2 Open the right housing cover to access print assembly (1, Figure 6-6) and disengage print head latch (2).
- 3 Loosen one of the two set screws (3) and move the free end of ribbon guide (4) upward or downward as necessary until the ribbon appears to unwrinkle.
- 4 Retighten loose set screw (3) while holding ribbon guide (4) in place.
- 5 Engage print head latch (2), close cover, and test print a label.
- 6 Repeat steps 2 through 5 until proper adjustment is achieved.

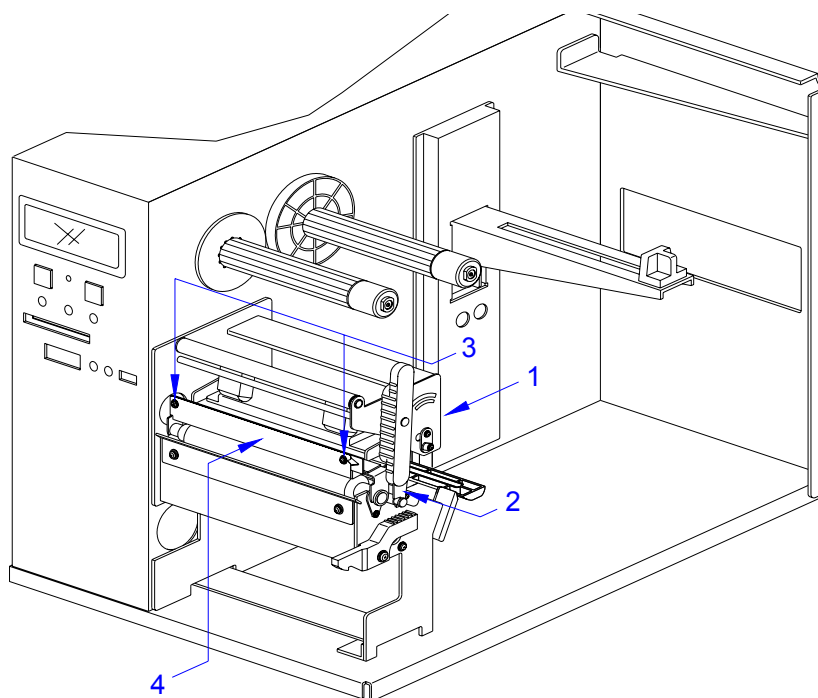

**Figure 6-6, Ribbon Guide Alignment**

## LABEL SENSOR POSITIONING

The label sensor assembly provides a mounting apparatus for the eye-mark, gap, and paper-end sensors. Position adjustment of the label sensor is not required when using standard label media.

When non-standard media is used, place a section of the media on the media ramp oriented as if loaded for printing. Manually grasp the sensor assembly and move it laterally so that the sensor indicators embossed in its side are aligned with the reference marks on the media.

- 1 Open the right housing cover to access print assembly (1, Figure 6-7).
- 2 Find label sensor adjustment knob (2) located behind lower print assembly (1).

**NOTE:** The label sensor adjustment knob is green colored ABS plastic.

- 3 Manually move knob (2) to the left or right as required to properly position label sensor (3).

**NOTE:** There are two lines on the front face of the label sensor. The line closer to the printer's center frame references the location of the eye-mark sensor, the one furthest out references the gap sensor. Adjust according to the type of media to be used.

**NOTE:** Sensor positioning may also be achieved by measuring from the printer's center frame outward to the specified distance for sensor/reference mark alignment. Refer to Figure 9-3 in the Appendix unit of this manual for applicable dimensions.

- 4 Test print a label to determine if label sensor (3) is properly aligned.

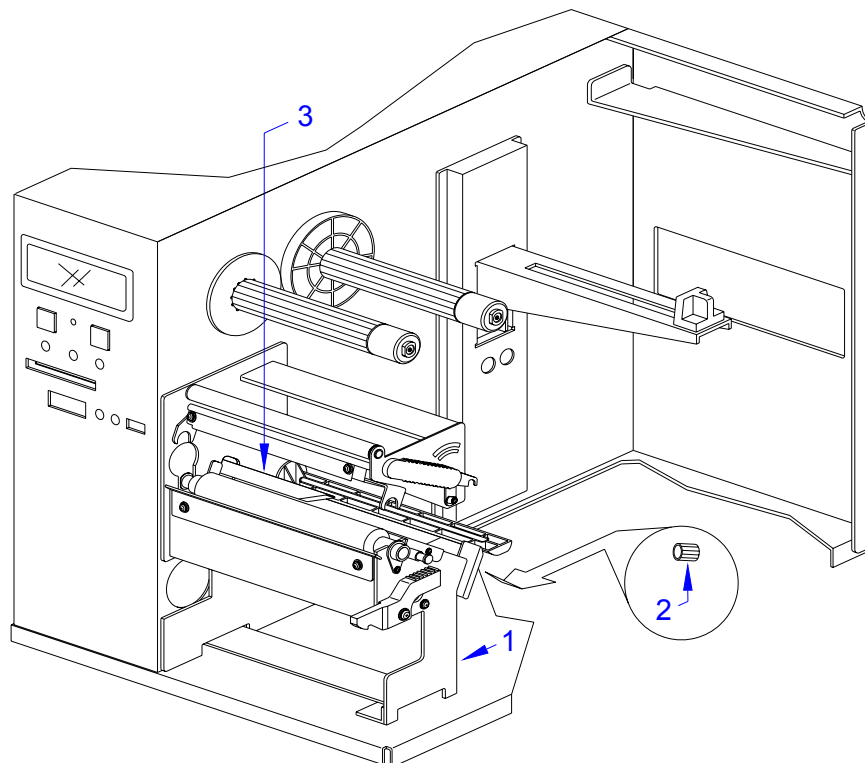

**Figure 6-7, Label Sensor Positioning**

## RIBBON SPINDLE TENSIONING

The printer has two ribbon spindles; one to supply ribbon medium from the rear of the printer past the print head to the spindle closest to the front for the purposes of rewinding the used medium. The rewind spindle is coupled to the drive train and draws the ribbon medium forward incrementally with the print media (label/tag) comparable with gearing ratios.

For a proper function, the spindles must be individually adjusted with the correct drag. Drag is the resistance to the advancement of the medium and is controlled by increasing or decreasing frictional tension to rotational movement. A torsion spring takes up excess slack in the ribbon medium during backfeed movement of the print media.

The following procedure explains how to adjust the ribbon spindles without the use of a tension gage. The procedure is the same for both, however, the tension requirements are different.

NOTE: The tension requirement for the supply spindle is 400-500 grams and 500-700 grams for the rewind spindle should a tension gage not be available.

To tension adjust the ribbon spindles without the use of a tension gage, perform the following.

- 1 Open the right housing cover to access the ribbon spindle assemblies.
- 2 Loosen the set screw while holding the adjustment nut stationary.
- 3 Turn the adjustment nut in a manner to achieve the required space between the ribbon boss and the stopper collar (supply spindle: 3.5 to 3.0, rewind spindle: 3.0 to 2.0 mm).
- 4 Hold the adjustment nut in position and secure set screw.
- 5 Repeat 2 through 4 for the remaining spindle.

NOTE: A complete revolution of the adjustment nut equals approximately 1 mm (100g). Likewise, a half revolution equals .5 mm (50g).

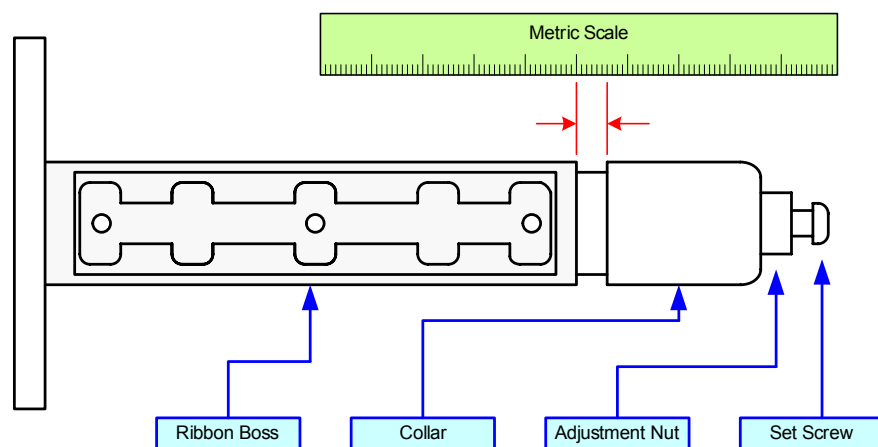

Figure 6-8, Ribbon Spindle Tensioning

## OPERATIONAL ADJUSTMENTS

These operational adjustments are for fine tuning the printer as necessary following the configuration process and are largely confined to the four potentiometers located on the operator panel. Refer to the table below for their function.

POTENTIOMETER	DESCRIPTION/PROCEDURE
PITCH	<p>Is to be used in conjunction with the configuration adjustments. Make course adjustments there and then fine tune here. If unable to achieve the desired setting here, the course adjustment must be reset. Adjust this potentiometer as labels are being printed. Allow two labels to be printed for each adjustment to ensure a desired setting.</p> <p>Adjustment of the PITCH potentiometer will affect the print offset position.</p>
OFFSET	<p>The offset adjustment is used to reposition the media for printing following advancement for dispensing. A label is printed, it is fed forward for dispense, the printer retracts the remaining media (offset) to print the next label. To perform this adjustment:</p> <ol style="list-style-type: none"> <li>1. Power On the printer.</li> <li>2. Press the LINE key to place printer offline.</li> <li>3. Advance to the User Mode and press FEED.</li> <li>4. Adjust the OFFSET potentiometer.</li> <li>5. Press the FEED key to feed another label.</li> <li>6. Repeat steps 3 and 4 until properly adjusted.</li> <li>7. Press the LINE key to bring the printer back online.</li> </ol>
DARKNESS	<p>Is used to adjust the darkness or lightness of the printed image and should be used in conjunction with the configuration adjustments. Make course adjustments there and then fine tune here. If unable to achieve the desired setting here, the course adjustment must be reset.</p> <p>Adjust this potentiometer as labels are being printed. Allow two labels to be printed for each adjustment to ensure a desired setting.</p>

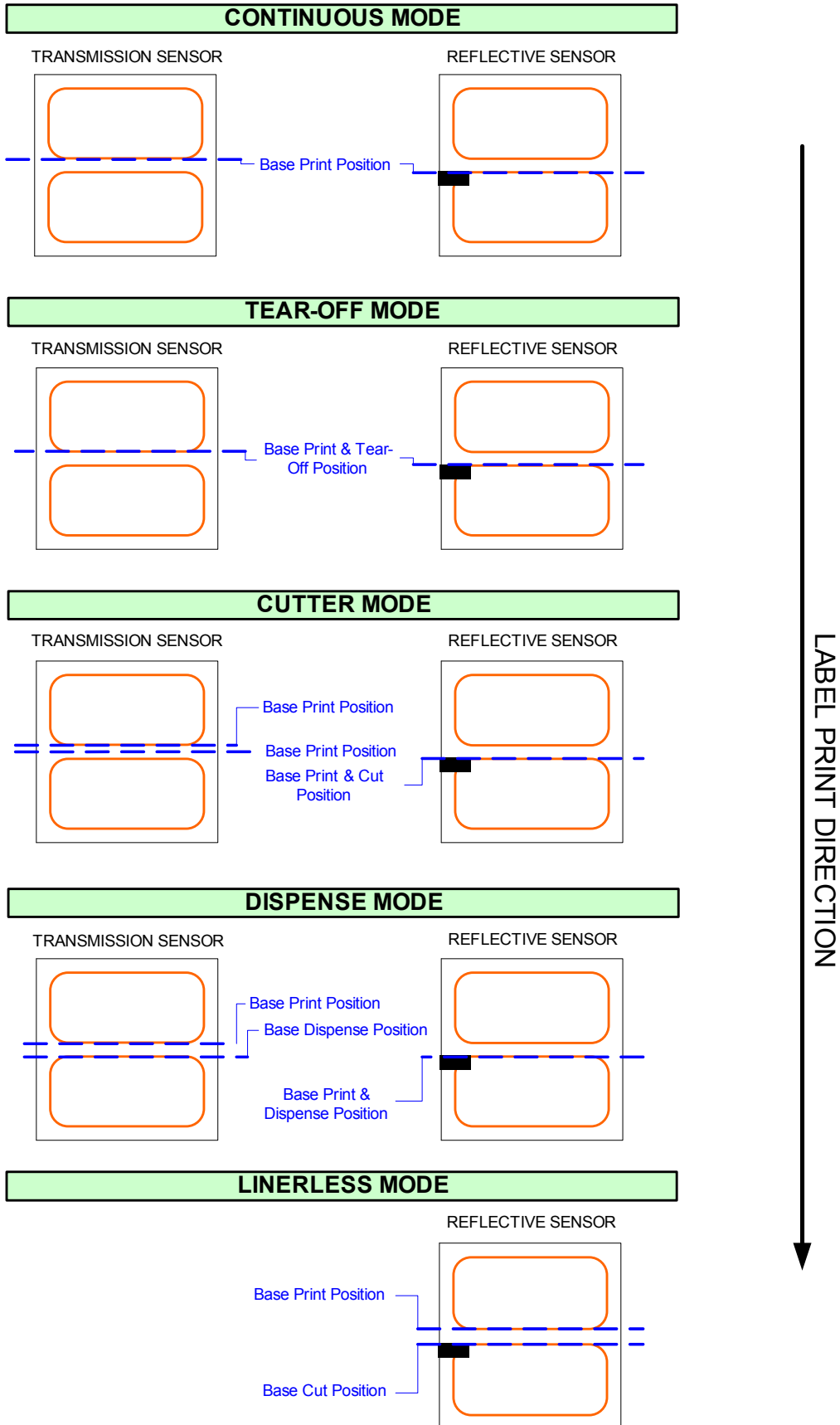

Figure 6-9, Print Base Reference Position

# 7

## **APPENDIX**

- **Print Setup Dimensions**
- **Label Reference Position Diagram**
- **Glossary**

# PRINT SETUP DIMENSIONS

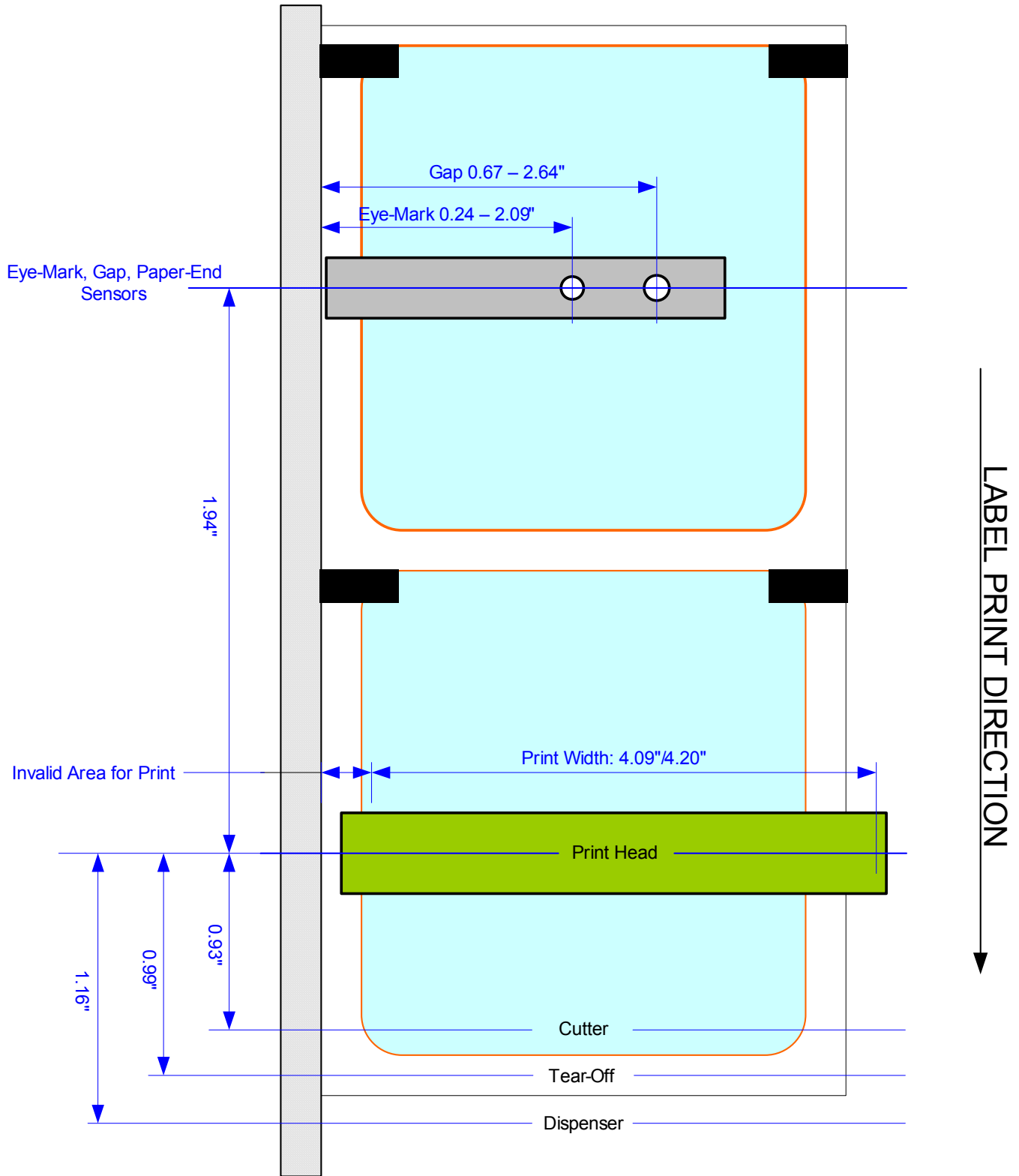

Figure 7-1, Print Setup Dimensions

# LABEL REFERENCE POSITION

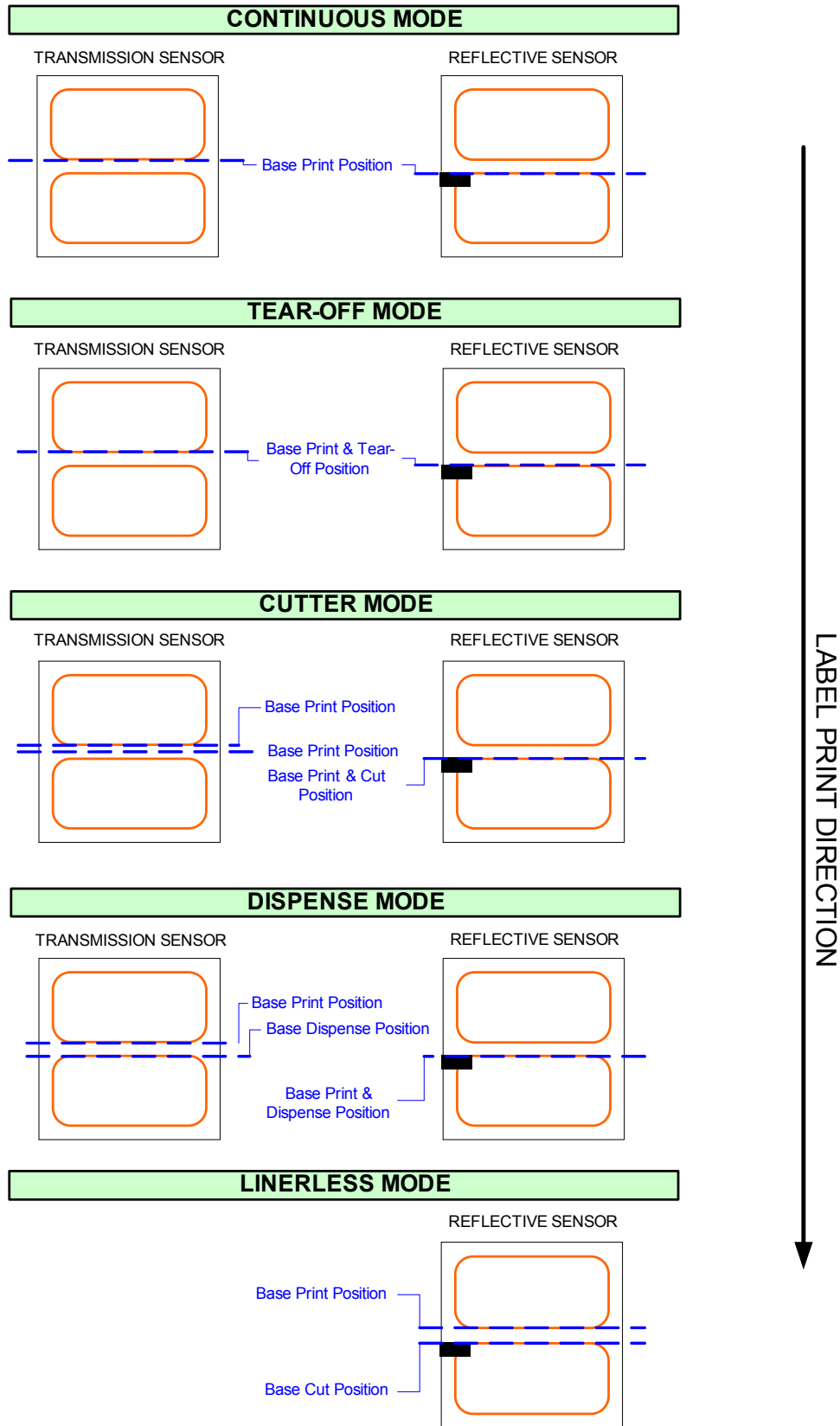

Figure 7-2, Label Reference Position Diagram



# GLOSSARY

GLOSSARY	
AC	(Alternating Current) Electrical current that reverses its direction regularly and continually.
Accessory	An optional assembly that may be used to provide an additional function.
Active Tags	RFID tags which use batteries as partial or complete source of power which are further differentiated by separating them into those with replaceable batteries and those which have the batteries inside a sealed unit. Also referred to as Utilized Active Tags.
Addressability	The ability to address bits, fields, files, or other portions of the storage in an RFID tag.
Advance	To bring forward - the opposite of retract.
Allen Screw	A screw whose head has a hexagonal recess to be driven by an allen wrench.
Aluminum	A silvery, light-weight, metal that resists corrosion.
Anti-Static	Resists static electricity.
Arc	A bow-like curved line or object.
	The band of sparks between to closely placed electrodes when current leaps the gap from one to the other.
ASCII	(American Standard Code for Information Interchange) The most common format for text files in computers and on the internet. In a ASCII file, each alphabetic, numeric, or special character is represented with a 7-bit binary number (a string of seven 0s or 1s). 128 possible characters are defined.
Assembly	The fitting together of parts, components, or sub-assemblies to form a complete unit.
Asynchronous	A type of two-way communication that occurs with a time delay, allowing participants to respond at their own convenience. This communication allows characters to be sent at irregular intervals by preceding each character with a start bit and following it with a stop bit. The timing of the transmission is not determined by the timing of the previous character.
Audible	A sound loud enough to be heard.
Batch	A grouping of anything.
Baud	<p>The number of signaling elements that occur each second; or stated differently, the number of changes to the transmission media per second in a modulated signal.</p> <p>At slow speeds, one bit of information (signaling element) is encoded in each electrical change. The baud therefore, indicates the number of bits per second (bps) that are transmitted.</p> <p>Assuming asynchronous communication, which requires 10 bits per character, this translates to 30 characters per second (cps). For slow rates, (below 1200 baud), the baud can be divided by 10 to see how many characters per second are sent.</p> <p>At higher speeds, it is possible to encode more than 1 bit in each electrical change. Thusly, 4800 baud may allow 9600 bits to be sent each second.</p> <p>At high data transfer speeds, data transmission rates are usually expressed in bits per second (bps) rather than baud.</p>
Bi-Directional	Capable of operating in two directions along the same plane or medium. In the case a communication cable or an RFID tag, one that transmits as well as receives, read and written.
Binary	A numeral system that represents numeric values using two symbols, typically 0 and 1. A binary number can be represented by any sequence of bits (binary digits), which in turn may be represented by any mechanism capable of being in two mutually exclusive states.
Bits	Refers to a single digit in the binary numeral system. A bit can either be <i>on</i> or <i>off</i> - a 1 or 0. A byte is a collection of eight bits.
Block Diagram	Shows the interconnections between system components by using a pictorial representation of a system and sub-systems linked to illustrate their relationships.
Bolt	A threaded metal rod with a flanged head that is used with a nut to hold parts together.
Bore	A hole in, or through something.

<b>GLOSSARY</b>	
Bytes	A collection of 8 bits used in the binary system.
Capacity	As it relates to RFID, the number of bits or bytes that can be programmed into a tag. This may represent the bits accessible to the user or the total number - including those reserved to the manufacturer (e.g., parity or control bits).
Capture Window/Field	Region of the scanner field in which an RFID tag will operate.
Cavity	A recessed area in something. In the case of a die set, the core is one of two part with the core being its mating half.
Chamfer	To slice off the corners of an angle to create a beveled edge.
Character	Any single numeral, letter, or symbol.
Chassis Assembly	A group of components or sub-assemblies that comprise the base of an assembly.
Circumference	The periphery of a circle or other rounded object - also the measurement of this distance.
Circuit	A network of wires, resistors, and other electronic devices over which electrical impulses travel.
Clockwise	To rotate from left to right.
Closed Systems	As it relates to RFID, a system in which relevant data regarding the attributes of the object is stored in a common database accessible via data link by referencing the individual ID code.
Collar	A sleeve applied to a rod, shaft, or pipe to prevent sideward motion.
Component	A single part that may applied to others to form an assembly.
Composite	An object that is comprised of, or layered with, two or more materials to achieve a desired outcome.
Concave	A curved recess or hollow - the opposite of convex.
Concentric	Multiple items that share a common center - example: a circle centered within a circle.
Configuration	The arrangement of parts or components to operate in unison for a specific activity.
	To program software to enable, disable, or specify how various features will function.
Connector	Devices for joining electrical and electronic circuits through coupling. Typically, one mating half is a plug (male) and the other is a socket (female).
Convex	A spherical shaped surface - one that is curved outward.
Core	The protruding portion of a die set. The core is one of two parts and the cavity being its mating half. The core is convexed and the cavity is concaved.
CPU	(Central Processing Unit) A programmable device that performs all the instruction, logic, and mathematical processing in a computer - is the brains of the computer. The CPU is a microchip that is installed on a motherboard (primary board) that coordinates hardware components. Also referred to as "processor".
Counter-Clockwise	To rotate from right to left.
Couple	Two mating halves that are connected - example: a plug or receptacle.
Cubic	The X, Y, and Z axis all being equal in size - a three-dimensional object that is equally proportioned.
Current	The flow or rate of flow of electric force.
Cycle	A single revolution of a potentially reoccurring activity - in the case of printer, one label being printed.
DC	(Direct Current) Electrical current flowing in a single direction.
Density	The quantity within a given or specific area or unit.
Deviation	A change in course or the measurement of that change.
Diameter	A straight line from the outer edge of a circle, through the center, and onward to the opposite edge. Also the measurement of that distance (dimension).
Dimension	Any measurable distance.

<b>GLOSSARY</b>	
Diode	Allows current to flow in one direction but not the other to protect sensitive electronics. A diode functions by compositing two conductive materials with one possessing low resistance to electrical current on one side and high resistance on the other.
Dipswitch Complex	A group of tiny switches directly attached to a circuit board to enable configuration for a particular type of application. These switches are two-position: On/Off.
Direct Thermal	The printing method that uses a chemically coated heat sensitive media. Once the heat from the thermal printhead is applied to the media, the media darkens with the image. Direct thermal printing does not require ribbon and is typically used in applications where the label needs to endure for a year or less.
Disable	To deactivate or make unable to function.
Divergent	To deviate from the norm or to possess opposing positions.
DPI	(Dots Per Inch) The quantity of printed dots within a square inch area - the print density.
DRAM	(Dynamic Random Access Memory) DRAM is the most common kind of RAM and is a network of electrically-charged points in which a computer stores quickly accessible data in the form of 0s and 1s. Each storage or memory cell can be directly accessed if the intersecting row or column is known. Each cell consists of a capacitor and a transistor.
Drive Train	The components and sub-assemblies that comprise the mechanical apparatus of motion or kinetic energy.
Eccentric	Multiple items that do not share the same center - example: a circle whose center axis is not the same as that of another to whom it is connected. The opposite of concentric.
E-Clip	Type E snap ring.
EEPROM	(Electrically Erasable Programmable Read-Only Memory) Are ROM chips that do not have to be removed to be rewritten. Nor does the entire chip have to be completely erased to change a specific portion. Changing the contents does not require additional dedicated equipment. The localized application of an electric field to each cell erases the targeted cells which can be rewritten. Since only 1 byte can be changed at a time, EEPROM's are versatile but slow.
Electronic Label	A label that has an electronic RFID tag embedded within.
Electromagnetic Coupling	In RFID, a system that uses a magnetic field as means of transferring data or power.
Electrostatic Coupling	In RFID, a system which uses the induction of voltage on a plate as a means of transferring data or power.
Ellipse	An oval shape that is symmetrical on either side of its center when divided into quadrants.
Embossed	Characters or graphics that are raised above the remaining surface.
Enable	To activate or make able to function.
Encompass	To surround, encircle, or contain.
Error Correcting Code	(ECC) In RFID, supplemental bits in a data transfer used in conjunction with a polynomial algorithm in order to compute the value of missing or erroneous data bits. Example: for a 32-bit data transmission, seven additional bits are required.
Error Correcting Mode	Relative to RFID, a mode of data communication in which missing or erroneous bits are automatically corrected.
Error Correcting Protocol	Relative to RFID, the rules by which the error-correcting mode operates.
Error Management	In RFID, the techniques used to ensure that only correct information is presented to the system's user.
Error Rate	In RFID, the number of errors per number of transactions.
Exciter	In RFID, the electronics which drive an antenna. When coupled with antenna, they are collectively referred to as a scanner. Also referred to as a transmitter.
Expansion Port	A plug accessing additional I/O capability on a computer or peripheral device.
Eye-Mark Media	Print media with a mark on the paper backing between each label for the label sensor to read. This mark is used by the printer to identify the end of the printed label so that the next up can be properly positioned for printing.

<b>GLOSSARY</b>	
Factory Programming	Relative to RFID, the programming of information into a tag occurring as part of the manufacturing process resulting in a read-only tag.
Field Programming	In RFID, programming that usually occurs before the tag is installed on the object to be identified enabling the introduction of data relevant to the specifics of the application. However, the tag would typically have to be removed from its object.
Field Protection	In RFID, the ability to limit the operations that can be performed on portions of data fields stored in a tag.
Fillet	To round off the sharp edges of the angle.
Flange	The projecting rim of an object used to keep another object or objects in place.
Flash Memory	A form of rewritable memory chip that allows multiple memory locations to be erased or written in one programming operation. Flash Memory is very high-speed and non-volatile - does not need power to maintain the stored information. Its information is stored in an array of floating gate transistors called "cells".
Font	A type or style of letter or numeral characters used in written text.
Frequency	The number of times a signal executes a complete excursion through its maximum and minimum values and returns to the same value. The number of vibration cycles.
Gap Media	Print media with a space between each label where only the paper backing exists. The printer's sensor uses this "gap" to identify when the printed label ends and to properly position the next label for printing.
Gauge	A unit of measurement used to describe the nominal thickness of wire. The higher the gauge number, the smaller the diameter.
Gear	A system of toothed wheels meshed together so that the motion of one is passed on to the others.
Gigabytes	Used to describe data transfer rates or storage capacity of 1 billion bytes.
Groove	An elongated slot cut into an object.
Hertz	Radio waves or other electromagnetic radiation resulting from oscillations of electricity in a conductor. Also the measurement of those oscillations.
Hexidecimal	A numbering system composed of six letters (A-F) and ten numbers (0-9) used to condense binary numbers.
Hex Screw	A threaded rod having a flanged head that is comprised of six sides - a type of hardware used to attach two or more objects.
Hole	In engineering: a recess that does not penetrate completely through as a bore or orifice. Term may be casually used in lieu of a bore or orifice.
Horizontal	On a level plane ninety-degrees from vertical.
Hz	(Hertz) Radio waves or other electromagnetic radiation resulting from oscillations of electricity in a conductor. Also the measurement of those oscillations.
Icon	An image or picture that has a specific meaning.
I.D. Filter	In RFID, software that compares a newly read ID with those in a database or set.
Idle Gear	A toothed wheel that is not directly driven, but instead receives motion from another.
Idle Roller	A non-toothed wheel that is not driven - in the case of printers, it is typically used to provide tension on a timing belt. Also referred to as "tension roller".
Illuminate	To give or emit light.
Inductive Coupling	In RFID, systems that use the inducing of a current in a coil as a means of transferring data or power.
Intermittent	Stopping and starting again at intervals.
In-Use Programming	The ability to read from, and write to, an RFID tag while attached to its object.
Junction	A place or point of joining or crossing.
Kinetic	The science dealing with the motion of masses in relation to the forces acting on them.

<b>GLOSSARY</b>	
Key	The button on a panel that may be pressed to send an electrical signal to influence a predetermined activity.
Keyed	A physical object shaped in a manner so as to prevent unwanted movement or to ensure desired movement.
Kg	(Kilogram) A unit of weight measure within the metric system.
Kilo-Bytes	Used to describe data transfer rates or storage capacity of approximately 1000 bytes.
Knob	A rounded handle to facilitate the manual opening, closing, securing, or otherwise movement of the object to which it is attached.
Knurled	An item that has recessed grooves or elevated areas on its surface to increase manual grip.
Label	Print media that has been used or printed upon that has adhesive on one side.
LAN Interface	(Local Area Network) A computer network limited to the immediate area, consequently capable of transmitting data at a very fast rate. Usually the computer is limited to the same building, or floor of a building, as the periphery device.
Latch	An object that is designed to be moved from one position to another for the purpose of preventing or allowing the opening of another object.
Lateral	Movement to the left or to the right - horizontal movement.
LCD	(Liquid Crystal Display) A display technology involving optical glass panels whose opacity can be controlled by electrical signals. A liquid crystal surface is sandwiched between two polarizing panels and when voltage is applied to certain areas, the crystal darkens. A light source behind the panel transmits through the transparent crystals and is mostly blocked by the darkened ones.
LED	(Light Emitting Diode) A semiconductor light source that emits visible light or invisible infrared radiation. The color of the emitted light depends on the chemical composition of the semiconducting material used.
Lever	An object that turns on a fixed point usually to engage or disengage a latch.
Laminate	A film or sheet placed onto and adhered flatly over another material.
Life	Relative to RFID, the functional period within which maintenance, adjustment, and repair is not reasonably expected.
Linear	The measurement of length without consideration of other dimensions.
Linerless Media	Print media that does not have a space between each label as does the eye-mark and gap type media. This media is continuous and is divided based on printer programming.
Link	An active connection to another document, graphic, or address. By selecting the designated button, text, graphic, or screen location; one is taken to the predetermined linked location.
M	(Meter) A unit of measure in the metric system equal to 39.37 inches.
MB	(Megabytes) Used to describe data transfer rates or storage capacity of approximately 1 million bytes depending on the manner of compression.
MM	(Millimeter) A unit of measure in the metric system equal to 0.03937 (1/25) inches.
Media	In printing, a batch of unprinted labels or tags.
Megabytes	Used to describe data transfer rates or storage capacity of approximately 1 million bytes depending on the manner of compression.
Menu	A display of items that may be chosen.
Meter	A unit of measure in the metric system equal to 39.37 inches.
Millimeter	A unit of measure in the metric system equal to 0.03937 (1/25) inches.
Module	A self-contained unit that may be plugged into another unit to operate.
Multimeter	A device that is used to measure output units relating to electrical current.
Memory Card	Relative to RFID, a read/write or reprogrammable tag in credit card size.
Memory Modules	A read/write or reprogrammable RFID tag.
Mobile Inventory Vehicle	In RFID, a vehicle equipped with a system for locating tagged vehicles, containers, and other objects for the purpose of inventory control.

<b>GLOSSARY</b>	
Modulation	In RFID, the methods of altering carriers in order to transmit the encoded information.
Nest	A set of similarly shaped objects with one smaller and resting within the other.
Nominal	The point between a positive and negative deviation which is considered to be optimum.
Nut	A small metal block with a threaded hole through its center for screwing onto a bolt.
Nylon Material	A milky-white, synthetic material used in manufacturing that is purchased in blocks and machined to the desired shape - resembles plastic.
Offset	In label printing, it is the repositioning distance that the printer must make after advancing the printed label for cutting or dispensing. The offset is the distance that the media must be retracted following one of those activities so that printing may again take place.
Omni-Directional	The ability of an RFID tag to operate in any orientation.
Orientation	Having to do with the manner or angle of placement.
Orientation Sensitivity	In RFID, the range or measurement of decreased readability by non-optimal orientation.
Orifice	An opening for which something is to pass through - similar to a bore.
O-Ring	A typically circular object made of round, elastic material to provide a seal between two objects.
Oscillate	To move back and forth along a span.
Pan Head Screw	A threaded rod with a rounded, flanged head used to attach multiple object together.
Paper	In printing applications, the temporary backing for print media. The paper is removed following printing so the label may be applied.
Parallel	Objects extending in the same direction maintaining the same distance part.
Parallel Interface	An interface between computer and printer where the computer sends multiple bits of information to the printer simultaneously by sending each bit over a separate wire.
Parameter	The span or area that something is allowed to exist or operate.
Parity	A simple form of error checking that is used in serial communication. A parity bit is a binary digit that is added to a group of bits to detect the presence of an error. The parity bit take on the value of an 0 or a 1 to satisfy a constraint on the overall parity of a binary number. The parity scheme in use must be specified as even or odd. Parity is even if there are an even number of 1 bits, and odd otherwise. None may also be chosen.
Passive Tags	Passive RFID tags that do not contain an internal power source. They are externally powered and typically derive their power from the carrier signal radiated from the scanner.
PC	(Personal Computer) An electronic computing device that may be individually and independently used or coupled to other similar devices.
Perforation	A series of through-holes in a material to facilitate tearing apart.
Perpendicular	At right angles to a given line or plane - a vertical line is perpendicular to a horizontal one and vise-versa.
Phenolic Material	A black, synthetic material used in manufacturing that is purchased in blocks and machined to the desired shape - resembles plastic.
Pinion Gear	A smaller gear meshed with a larger one.
Pitch	Physical top of form of media placed under the print head elements in the feed direction.
Plastic	A synthetic material typically rigid in nature that is molded to its useful shape. Plastic is typically injection molded along with its color additive and may be of any color chosen.
Post	A pin or shaft to which an object may be tethered or latched.
Potentiometer	A variable resistor used to adjust voltage to affect various mechanical activities. This electronic component is comprised of two terminals connected to either end of an resistive element and a conductor that can be moved between the two ends, thus allowing the creation of a resistor or voltage divider.
Primary	Something first in order or importance.
Print Assembly	The sub-assembly of a printer that comprise the printing components.

<b>GLOSSARY</b>	
Print Head	The device on a direct thermal or thermal transfer printer containing the heating elements that causes an image to be transferred to print media.
Processor	A programmable device that performs all the instruction, logic, and mathematical processing in a computer - is the brains of the computer. The processor is a microchip that is installed on a motherboard (primary board) that coordinates hardware components. Also referred to as "CPU".
Profile	A side view of an item.
Program	To enter or send to the processor, the control parameters for electronic equipment to operate.
Proportional	To be equal.
Proximity Sensor	A device that detects and signals the presence of a selected object at, or near, the sensor's location.
Pulley	A toothed wheel for providing movement to a belt.
Quadrant	One quarter of the circumference of a circle.
Radial	Branching out in equal distances from a common center.
Radius	A straight line from the center of a circle or sphere to its periphery - also the measurement of its distance.
RAM	(Random Access Memory) A network of electrically-charged points in which a computer stores quickly accessible data in the form of 0s and 1s. Each storage or memory cell can be directly accessed if the intersecting row or column is known.
Ratio	The quotient of one quantity divided by another of the same kind.
Reader	Relative to RFID, a device containing the digital electronics which extract and separate the information from the format definition and error management bits.
Read/Write	Relative to RFID, many applications require that new data or revisions to data already in the tag, be entered while it remains on the object. Some items with this capability of being re-programmable are read/write tags, memory cards, or memory modules.
Receive Buffer	An area of temporary data storage to help compensate for differences in the transfer rate and the processing ability of the printer.
Receptacle	A female connector to which a male connector may be inserted - typically for electrical current.
Relay	A simple electro-mechanical switch made up of an electromagnet and a set of contacts. Relays use a small amount of power to energize things that require a greater amount of energy.  Sometimes relays are serial connected so that one smaller relay activates a larger relay which in turn, activates another larger still, and so on until the thing that is desired to be activated - is.
Retain	To keep or to hold in place.
Retract	To withdraw - the opposite of advance.
Resistor	A two-terminal electrical or electronic component that resists the flow of current producing a voltage drop between its terminals in accordance with Ohm's law. This electrical resistance is equal to the voltage drop across the resistor, divided by the current that is flowing through it.
RF/AIS	(Radio Frequency Automatic Identification Systems)
RF/DC	Systems that communicate over a radio link between a host computer and a data source. RF/DC enhances the capabilities of automatic ID Systems by providing the capabilities of hare-wire data communications without the physical restrictions interconnecting wires.
RFID	(Radio Frequency Identification) A method of identifying unique items using radio waves. Typically, a reader communicates with a tag, which holds digital information in a microchip. But there are chipless forms of RFID tags that use material to reflect back a portion of the radio waves beamed at them.

GLOSSARY	
RFID Tags	<p>A system of finding the position or location of assets.</p> <p>A microchip attached to an antenna that is packaged in a way that it can be applied to an object. The tag picks up signals from, and sends signals to, a reader. The tag contains a unique serial number, but may have other information and come in many forms, such as smart labels that can have a barcode printed on it, or can simply be mounted inside a carton or embedded in plastic. RFID tags can be active, passive, or semi-passive.</p> <p>Each tag broadcasts a signal to be received by three reader antennas. The time each signal is received is passed on to a software system that uses triangulation to calculate the location of the asset.</p>
Ribbon	A thin, flexible strip with layers of material; one of which contains ink used to produce an image on print media.
Ribbon Core	A thick cardboard sleeve onto which ribbon is wound.
Rigid	Not flexible - stiff.
ROM	<p>(Read-Only Memory) Also known as firmware, is an integrated circuit programmed with specific data when it is manufactured. There are five basic types: ROM, PROM, EPROM, EEPROM, and Flash Memory.</p> <p>Each type has unique characteristics, but they all are types of memory that have two things in common: the stored data is non-volatile (not lost when power is removed) and the stored data is unchangeable or requires a special operation to do so.</p> <p>ROM chips contain a grid of columns and rows. A diode is used to connect the lines and gain access to the data if the value is 1. If the value is 0, the lines are not connected and access is denied.</p>
RPM	(Revolutions Per Minute) The number of cycles within the time span of one minute.
Route	The path or course taken to get from one location to another - example: the routing of a cable within a machine.
SAM	(Serial Access Memory) Stores data as a series of memory cell that can only be accessed sequentially. Works very well for memory buffers where data is normally stored in the order in which they will be used.
SBPL	(SATO Basic Programming Language)
Scale	<p>The units to measure distance - or a short tool for measurement.</p> <p>To increase or decrease the proportionate size of an object - example: text or graphics on a printed label.</p>
Scanner	In RFID, an antennas transmitter and receiver electronics integrated in a single package.
Screen	An electronic display.
Seat	To nest or couple one object to another. The same as to nest.
Secondary	The next to follow the primary in sequence or importance.
SEMBL	A SATO specific mode of printer operation that can execute the program of BASIC format in the printer. This allows the printer to be configured and operated without interfacing with an external computer or software.
Sensitivity	The degree of ease or difficult to gain a response - example: a sensor transmitter signal may require increase to penetrate the thickness of print media in order to be receipted by its receiver.
Sensor	A device that responds to a physical stimulus and produces and electronic signal.
Separation	The operational distance between two RFID tags.
Sequential	One to follow another in a specified order - examples: 1, 2, 3; A, B, C.
Serial Interface	A general-purpose interface that can be used for almost any type of device in which only 1 bit of communication is transmitted at a time.
Set Screw	Attachment hardware specifically used to secure an object may be moved in a specific position or location.
Shaft	Any rod, bar, or tube.



GLOSSARY	
Simultaneous	To take place at the same time.
Sleeve	A thin hollow material that is inserted onto another to provide proportionate spacing.
Snap Ring	A circular clip that may be applied to a shaft, etc. to prevent another object from moving - used to retain objects in position.
Solid	An item that is not porous.
	An item that is not transparent or translucent.
Spacer	Any object of purpose to maintain a specific distance from two other objects - example: a sleeve or washer.
Spindle	A shaft or rod that is fixed on one or both ends and spins on its axis while maintaining its projection.
SRAM	(Static Random Access Memory) A type of memory that is faster and more reliable than the more common DRAM. The term <i>static</i> is derived from the fact that it doesn't need to be refreshed like DRAM.
Stainless Steel	A shiny, mirror-like carbon steel alloyed with chromium to inhibit rust.
Steel	Metal that contains a specific percentage of carbon. The percentage of carbon determines its strength, in addition to how prone it is to rust.
Stepper Motor	An electrical motor designed to rotate in both directions and to move in incremented distances.
Sub-Assembly	A group of components assembled to form a complete unit that is a part of a larger unit.
Switch	A small mechanical device when altered sends an electrical signal to influence a predetermined activity. Unlike a button or key, switches may have multiple positions.
Tag	Relative to RFID, the transmitter/receiver pair of transceiver plus the information storage mechanism attached to the object. Also referred to as Transponder.
Thermal Transfer	<p>The printing method that creates an image by transferring ink from a heat activated ribbon onto the media using the heat from a thermal printhead.</p> <p>A printhead is composed of a set of pins referred to as "elements" which may be selectively heated through electrical induction. Regular paper media is used in this application in conjunction with the heat sensitive ribbon. The ribbon deposits a coating of dark material onto the paper when exposed to intense heat.</p> <p>Thermal transfer printing is more durable than direct thermal printing and is often used when a label needs to endure longer than a year.</p>
Thermodynamics	The science that deals with the relationship of heat and mechanical energy - also the conversion of one into the other.
Threads	The spiral grooves on the shaft of a screw,
Three-Dimensional	The three projectories of an object: X axis is the distance left and right, the Y axis is the distance up and down, and the Z axis is the distance inward and outward.
Torsion Spring	A piece of wire bent into a spiral and connected on each end by different objects to allow them to be pulled apart and then automatically return to their original position once released.
Transformer	A device used to increase or decrease electricity's voltage and current. The device consists of one or more windings (typically copper) which, the ratio of the number of turns inversely determines the voltage change. The windings are wrapped around a magnetic core affecting magnetic induction.
Transistor	A device used to amplify a signal or open and close a circuit. Is constructed of a semiconductive material and is comprised of three terminals where one can be used to control the flow of current through the other two.
Translucent	When a medium is of a condition so as to allow light to filter.
Transparent	When a medium is of a condition so one can see through it unfettered.
Transponder	Relative to RFID, the transmitter/receiver pair of transceiver plus the information storage mechanism attached to the object. Also referred to as Tag.
Tread	The act of an object making repetitive contact upon another that is in motion.

<b>GLOSSARY</b>	
Troubleshoot	The act of locating the source of a problem or problems.
Two-Dimensional	Two of the projectories of an object: X axis is the distance left and right and the Y axis is the distance up and down. In a two-dimensional perspective, the Z axis is not recognized.
Uniform	The state of multiple objects being the same.
Units	Any fixed quantity, measure, etc.
USB Interface	(Universal Serial Bus) An external peripheral interface standard for communication between a computer and external peripherals over a cable using bi-serial transmission.
Value	The quantity for which a symbol stands.
Vertical	A plane or axis that is plum - the Y axis.
Voltage	The units of electrical force - the ampere current that flows through a conductor.
Volume	The amount of space occupied in three dimensions - cubic contents.
	The strength or loudness of sound.
Washer	A flat disk of metal, rubber, etc., used to make a seat for the head of a bolt, screw, or nut.
Wattage	The amount of electrical power to operate an electrically powered device - arrived by multiplying amperage by voltage.
Wear	To diminish in quality by repetitive activity.
Wireless	Operates with electromagnetic waves and not with conducting wire.
Wiring Harness	Multiple electrical wires bundled together.
X-ON/X-Off	A protocol for controlling the flow of data between computers and other devices on an asynchronous serial connection.
	For example, a computer typically sends data to a printer faster than the printer can print. The printer contains a buffer where data is stored until it catches up, a small microprocessor in the printer sends back an Xoff signal to stop sending data. When enough data is printed and the buffer storage becomes free, the printer sends an Xon signal to resume sending data.